



**FLECK** NXT TIMER  
SERVICE MANUAL



# TABLE OF CONTENTS

JOB SPECIFICATION SHEET ..... 2  
 TIMER OPERATION ..... 3  
 SYSTEM DEFINITIONS ..... 4  
 SYSTEM OPERATION IN SERVICE  
 (SYSTEM 14-DEMAND RECALL) ..... 5  
 FLOW IN A FOUR-UNIT SYTEM  
 (SYSTEM 14-DEMAND RECALL) ..... 6  
 TIMER DISPLAY FEATURES ..... 6  
 TIMER DISPLAY - SCREEN EXAMPLES  
 (SYSTEM 4 THROUGH 6) ..... 7  
 TRANSFORMER AND GROUND CONNECTIONS ..... 7  
 NETWORK/COMMUNICATION CABLES AND CONNECTIONS 8  
 MASTER PROGRAMMING MODE FLOW CHART ..... 8  
 USER PROGRAMMING MODE FLOW CHART..... 11  
 DIAGNOSTIC PROGRAMMING MODE FLOW CHART ..... 11  
 2750/2850/2900S UPPER & 2900S  
 LOWER POWERHEAD ASSEMBLY..... 13  
 3150/3900 UPPER & LOWER POWERHEAD ASSEMBLY ..... 15  
 METER ASSEMBLY PLASTIC ..... 17  
 1-INCH BRASS METER ASSEMBLY ..... 18  
 1-INCH STAINLESS STEEL METER ASSEMBLY ..... 19  
 1-1/2 INCH BRASS METER ASSEMBLY ..... 20  
 1-1/2 INCH STAINLESS STEEL METER ASSEMBLY ..... 21  
 2 INCH BRASS METER ASSEMBLY..... 22  
 2 INCH STAINLESS STEEL METER ASSEMBLY ..... 23  
 3 INCH BRASS METER ASSEMBLY..... 24  
 3 INCH STAINLESS STEEL METER ASSEMBLY ..... 25  
 SINGLE PISTON WIRING DIAGRAM..... 26  
 DUAL PISTON WIRING DIAGRAM ..... 27  
 REMOTE TIMER WIRING DIAGRAM ..... 28  
 2750/2850 REMOTE TIMER WIRING DIAGRAM ..... 29  
 2900 REMOTE TIMER WIRING DIAGRAM ..... 30  
 3900 REMOTE TIMER WIRING DIAGRAM ..... 31  
 3150 REMOTE METER WIRING DIAGRAM ..... 32  
 TROUBLESHOOTING..... 33

# JOB SPECIFICATION SHEET

Please Circle and/or Fill in the Appropriate Data for Future Reference:

**Programming Mode:**

Feed Water Hardness: \_\_\_\_\_ Grains per Gallon or mg CaCO<sub>3</sub>/L  
 Regeneration Time: Delayed \_\_\_\_\_ AM/PM or Immediate  
 Regeneration Day Override: Off or Every \_\_\_\_\_ Days

**Master Programming:**

System Type:  
 4 - Single Unit  
 5 - Parallel Unit  
 6 - Parallel Series Regen  
 7 - Twin Alternating  
 9 - Alternating  
 14 - Demand Recall

Valve Type: 2750 2850 2900s 3150 3900  
 System Size: 1 Valve 2 Valves 3 Valves 4 Valves  
 Valve Address: #1 #2 #3 #4

Regenerant Flow: Downflow or Upflow  
 Brine Draw First or Brine Fill First

Display Format: US Gallons or Liters  
 Unit Capacity: \_\_\_\_\_ Grains or grams CaCO<sub>3</sub>  
 Capacity Safety Factor: Zero or \_\_\_\_\_ %

Trip Points (Gallons or M<sup>3</sup>): \_\_\_\_\_ Point 1 \_\_\_\_\_ Point 2 \_\_\_\_\_ Point 3  
 Trip Delays: \_\_\_\_\_ Delay 1 \_\_\_\_\_ Delay 2 \_\_\_\_\_ Delay 3

Regeneration Cycle Step #1: \_\_\_ : \_\_\_ : \_\_\_  
 Regeneration Cycle Step #2: \_\_\_ : \_\_\_ : \_\_\_  
 Regeneration Cycle Step #3: \_\_\_ : \_\_\_ : \_\_\_  
 Regeneration Cycle Step #4: \_\_\_ : \_\_\_ : \_\_\_  
 Regeneration Cycle Step #5: \_\_\_ : \_\_\_ : \_\_\_

Timed Auxiliary Relay Output Window:  
 Off or Start Time \_\_\_ : \_\_\_ : \_\_\_  
 End Time \_\_\_ : \_\_\_ : \_\_\_

Chemical Pump Output Auxiliary Relay:  
 Off or Volume (Gallons or Liters) \_\_\_\_\_  
 Time \_\_\_ : \_\_\_ : \_\_\_

Fleck Flow Meter Size:  
 Paddle: 1" 1.5" 2" 3"  
 Turbine: 1" 1.5"

Generic Flow Meter:  
 Maximum Flow Rate:  
 Add \_\_\_ Gallons every \_\_\_ Pulses



**IMPORTANT PLEASE READ:**

- The information, specifications and illustrations in this manual are based on the latest information available at the time of printing. The manufacturer reserves the right to make changes at any time without notice.
- This manual is intended as a guide for service of the controller only. System installation requires information from a number of suppliers not known at the time of manufacture. This product should be installed by a plumbing professional.
- This unit is designed to be installed on potable water systems only.
- This product must be installed in compliance with all state and municipal plumbing and electrical codes. Permits may be required at the time of installation.
- If daytime operating pressure exceeds 80 psi, nighttime pressures may exceed pressure limits. A pressure reducing valve must be installed.
- Do not install the unit where temperatures may drop below 32°F (0°C) or above 110°F (43°C).
- Do not place the unit in direct sunlight. Black units will absorb radiant heat increasing internal temperatures.
- Do not strike the controller or any of the components.
- Warranty of this product extends to manufacturing defects. Misapplication of this product may result in failure to properly condition water, or damage to product.
- A prefilter should be used on installations in which free solids are present.
- Correct and constant voltage must be supplied to the controller to maintain proper function.

## TIMER OPERATION

### Setting the Time of Day

**NOTE: Set Time of Day on the Lead Unit (#1) and the rest of the units in the system will update the Time of Day within 10 seconds.**

1. Press and hold the Up or Down button for 2 seconds.
2. Press the Shift button to select the digit you want to modify.
3. Press the Up or Down buttons to adjust the value.
4. Press the Extra Cycle button to return to the normal display screen, or wait for a 5 second timeout.

**NOTE: The "D" button (Diagnostic) can be pressed to exit without saving.**

### Manually Initiating a Regeneration

1. When timer is In Service or Stand By, press the Extra Cycle button for 5 seconds on the main screen.
2. The timer advances to Regeneration Cycle Step #1, and begins programmed time count down.
3. Press the Extra Cycle button once to advance valve to Regeneration Cycle Step #2 (if active).
4. Press the Extra Cycle button once to advance valve to Regeneration Cycle Step #3 (if active).
5. Press the Extra Cycle button once to advance valve to Regeneration Cycle Step #4 (if active).
6. Press the Extra Cycle button once to advance valve to Regeneration Cycle Step #5 (if active).
7. Press the Extra Cycle button once more to advance the valve back to In Service.

**NOTE: A manually initiated or queued regeneration can be cleared by pressing the Extra Cycle button for less than 5 seconds. A system queued regeneration can only be cleared by stepping through a manual regeneration. If regeneration occurs for any reason prior to the delayed regeneration time, the manual regeneration request shall be cleared. Pressing the Extra Cycle button while in regeneration will cause the upper drive to advance to the next step immediately.**

### Timer Operation During Regeneration

In the Regeneration Cycle step display, the timer shows the current regeneration cycle number the valve is in, or has reached, and the time remaining in that step. Once all regeneration steps are complete the timer returns to In Service and resumes normal operation.

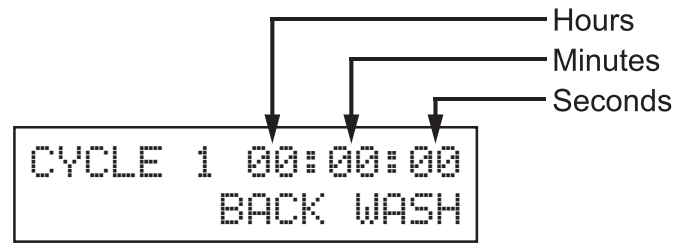

**Example:** 12 minutes remaining in Cycle 1 (Backwash)



Press the Extra Cycle button during a system queued Regeneration Cycle to immediately advance the valve to the next cycle step position and resume normal step timing.

### Flow Meter Equipped Timer

As treated water is used, the Volume Remaining display counts down from the calculated system capacity to zero. When zero is reached a Regeneration Cycle begins if no other units are in regeneration.

### Timer Operation During Programming

The timer enters the Program Mode in Standby or Service Mode as long as it is not in regeneration. While in the Program Mode the timer continues to operate normally monitoring water usage. Timer programming is stored in memory permanently.

### Timer Operation During A Power Failure

All program settings are stored in permanent memory. Current valve position, cycle step time elapsed, and time of day are all stored during a power failure, and will be restored when power is re-applied. Time is kept during a power failure, and time of day is adjusted upon power up (as long as power is restored within 12 hours).

**NOTE: The time of day on the main display screen will flash for 5 minutes when there has been a power outage. The flashing of the time of day can be stopped by pressing any button on the display.**

### Remote Lockout

The timer does not allow the unit/system to go into Regeneration until the Regeneration Lockout Input signal to the unit is cleared. This requires a contact closure to activate the unit. The recommended gauge wire is 20 with a maximum length of 500 feet. See P4 remote inputs in the wiring diagrams in the service manual.

### Regeneration Day Override Feature

If the Day Override option is turned on and the valve reaches the set Regeneration Day Override value, the Regeneration Cycle starts if no other unit is in Regeneration. If other units are in regeneration, it is added to a regeneration queue. This occurs regardless of the remaining volume available.

**⚠ WARNING: Transformer must be grounded and ground wire must be terminated to the back plate where grounding label is located before installation.**

## SYSTEM DEFINITIONS

System Number	System Description	# of Tanks/ Controls	Type	Operation Discussion
4	Single Unit	1	Time Clock: No Meter Immediate: One Meter Delayed: One Meter Remote Signal Start: No Meter	Single tank configuration.
5	Interlocked	2, 3, or 4	Immediate: All Meters Remote Signal Start: No Meter	All tanks in parallel supplying treated water. Each unit in the system will have its own flow meter/sensor input. The control will delay the start of Regeneration if another unit is already in Regeneration. Once that unit has completed a Regeneration cycle, and has returned to Service, the unit with longest regeneration queue time will begin Regeneration. No more than one unit will be in Regeneration at a time.
6	Series Regeneration	2, 3, or 4	Immediate: One Meter Delayed: One Meter Remote Signal Start: No Meter	All tanks in parallel supplying treated water. Only #1 control will monitor flow meter/sensor input. When a regeneration is required for the system, it will regenerate valve address #1 first, immediately followed by #2, then #3, then #4 if installed. No more than one unit will be in Regeneration at a time.
7	Twin Alternating	2	Immediate: One Meter Remote Signal Start: No Meter	One tank online supplying treated water, one tank in Standby. Only #1 control will monitor its flow meter/sensor input. Regeneration of a unit will begin after the other control has left Standby and returned to Service. When the Regeneration cycle is complete, the regenerated unit will enter Standby. Standby on each tank is controlled by the lower drive output terminals on the NXT circuit board.
9	Multiple Tank Alternating	2, 3, or 4	Immediate: All Meters Remote Signal Start: No Meter	One, two, or three tanks online supplying treated water, one tank in Standby. Meter/sensor input is required on each tank. Regeneration of a unit will begin after the other control has left Standby and returned to Service. When the Regeneration cycle is complete, the regenerated unit will enter Standby. Standby on each tank is controlled by the lower drive output terminals on the NXT circuit board.
14	Demand Recall	2, 3, or 4	Immediate: All Meters	Meter input is required on each tank. Unit #1 will begin In Service with #2, #3, and #4 (if installed) will begin in Standby. At least one unit is In Service at all times. When flow rate to the Primary Service Unit increases to a user specified rate, the next unit in sequence will move from Standby to Service. As the flow rate falls below the user specified rate subsequent tanks will return to Standby. When the Primary Service Unit regenerates, the next unit in sequence will become the new Primary Service Unit. As each units capacity is reached the controller will initiate a Regeneration of that unit. Depending on the number of units in the system, and flow rate demand the regenerated unit will then be placed either into Standby or Service. Only one unit will be in Regeneration at a time.

# SYSTEM OPERATION IN SERVICE (SYSTEM 14-DEMAND RECALL)

The system operates as part of a multi-valve regeneration system.

Each valve in the system will have an active flow meter input, even in Standby.

The number of valves in service depends on the flow rate.

## Examples of a Four-Unit System:

1. One Valve is in service at all times (the "primary valve").

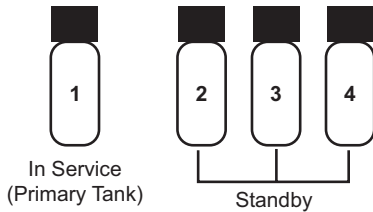

2. The total flow rate to the primary valve increased past the first trip point programmed rate. The flow stayed past the trip point delayed time. The next valve (least volume remaining) changes from Standby to In Service. This valve then splits the total flow between two meters.

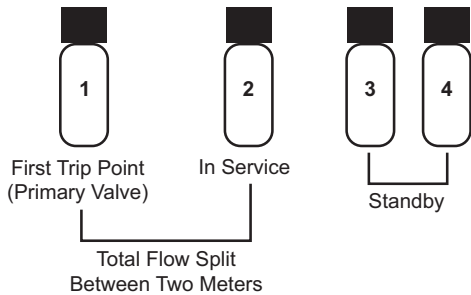

3. The flow rate demand decreased below the first trip point. The valve returns to Standby.

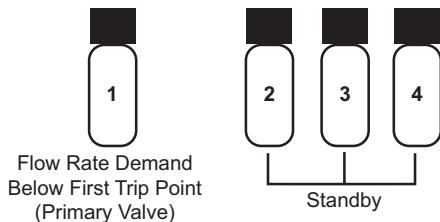

4. Total flow rate demand increased past a second trip point programmed rate. The second and third valve (least volume remaining) changes from Standby to In Service. The total flow is split between the three meters.

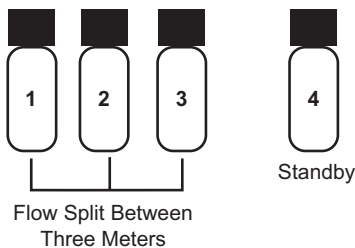

5. The third valve returns to standby as demand decreases past the second trip point.

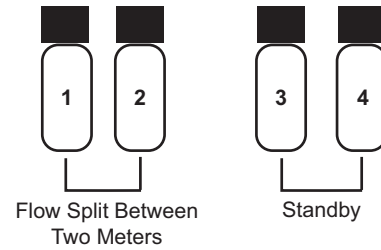

6. Valves return to standby due to decreased total flow rate and trip points programmed. The valve with the most remaining volume will be the first to go into Standby.

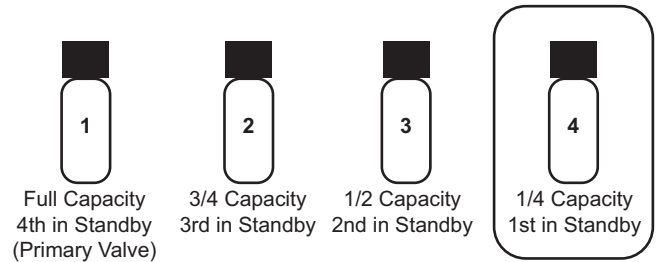

7. The primary valve regenerates. The next valve with the least remaining volume becomes the new primary valve. The valve with the next least volume remaining will be the first trip point programmed rate. Valves continue operating in this order.

## System Operation in Regeneration:

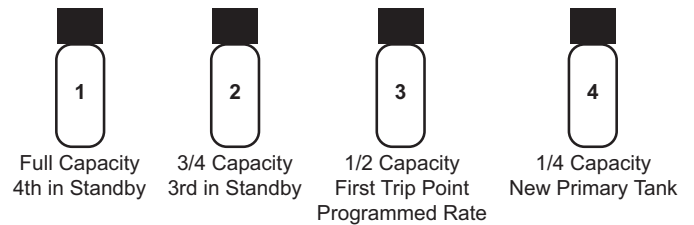

If two valves are In Service and both reach Volume Remaining = 0, the other two valves will shift from Standby to In Service. The lead valve with Volume Remaining = 0 will start regeneration. The second valve with Volume Remaining = 0 will enter Standby. If flow increases past the trip point a third valve needs to enter In Service. The valve in Standby with Volume Remaining = 0 will shift into In Service to maintain a steady flow. Operating for extended periods in this mode may degrade the water quality.

# FLOW IN A FOUR-UNIT SYTEM (SYSTEM 14-DEMAND RECALL)

## Steady Flow:

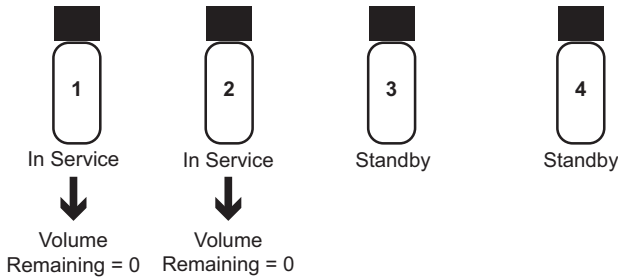

## Flow Stays Steady:

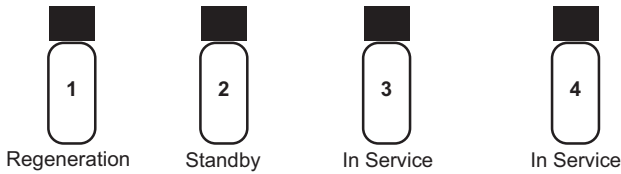

## Flow Increases Past the Trip Point:

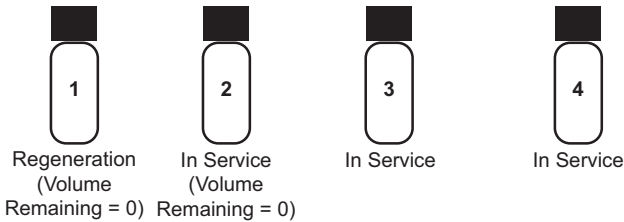

# TIMER DISPLAY FEATURES

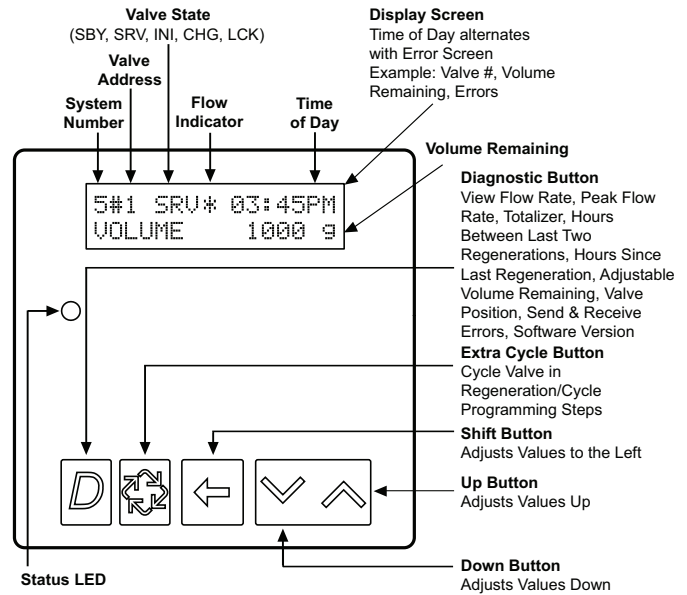

Figure 1

## Valve State

**CHG (Change of State)** - CHG will be displayed when the lower drive changes from one state to another in dual piston valves.

**INI (Initializing)** - INI will display on the screen for 30 to 45 seconds when initializing after a power failure reset or programming.

**RGQ (Regeneration Queued)** -RGQ indicates that the reserve has been entered in a delayed system and regeneration has been queued. When in the main screen, press the Extra Cycle button to toggle service (SRV) with RGQ.

**Service (SRV)** - SRV will display when the unit is in service.

**LCK (Lock)** - Lock will be displayed when the terminal/remote input block P4 on the circuit board is switched to "lock". See the "Wiring Diagrams" section of this manual.

## LED Status Lights

**Blue LED** - Illuminates while the unit is in service and no errors exist. A blinking blue light indicates the timer is in service, and queued for regeneration.

**Green LED** - Illuminates when the unit is in Regeneration mode, unless an error condition exists. A blinking green light indicates the timer is in Standby, and not in Regeneration.

**Red LED**- Illuminates when there is an error.

## Flow Indicator

A rotating line (appearing as a rotating star shape) will display on the screen when flow is going through the meter.

## TIMER DISPLAY - SCREEN EXAMPLES (SYSTEM 4 THROUGH 6)

1. In Service: System 4 Time Clock

```
4#  SRV  03:45PM
REGEN IN 07 DAYS
```

2. In Service: System 4 Flow Meter Initiated or System 4 Flow Meter Delayed

```
4#  SRV* 03:45PM
VOLUME 1000 ☺
```

3. In Service: System 5 Flow Meter Initiated (Lead Unit)

```
5#1 SRV* 03:45PM
VOLUME 1000 ☺
```

4. In Service: System 5 Flow Meter Initiated (Lag Unit #3)

```
5#3 SRV  03:45PM
VOLUME 1000 ☺
```

5. In Service: System 6 Flow Meter Initiated (Lead Unit)

```
6#1 SRV* 03:45PM
SYSVOL 4000 ☺
```

## TRANSFORMER AND GROUND CONNECTIONS

### 2750/2850/2900 Valves:

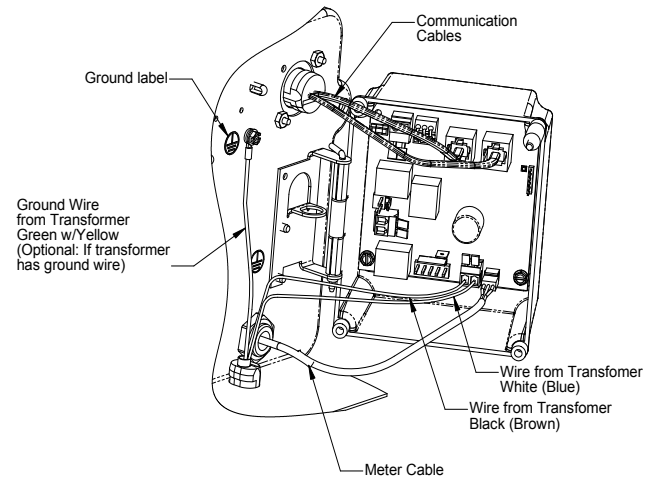

### 3150/3900 Valves:

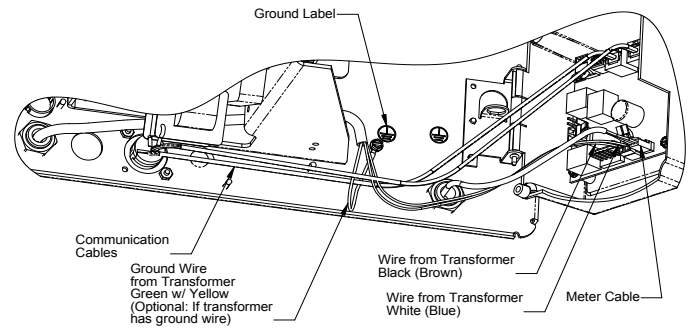

**IMPORTANT: Earth ground wire must be installed.**

### Installing the Transformer:

1. Locate the ground label to find the screw to attach the ground wire on the transformer.
2. Remove the screw and attach the ground wire, and re-attach the screw.
3. Insert white and black transformer wires into 24VAC input of control.

## NETWORK/COMMUNICATION CABLES AND CONNECTIONS

Use either a CAT3 or CAT5 Network/Communication cable. Connect the network/communication cable first before programming.

The maximum cable length between timers is 100 feet.

Connect each unit together from one communication port to the next communication port. It does not matter which one goes to the next one.

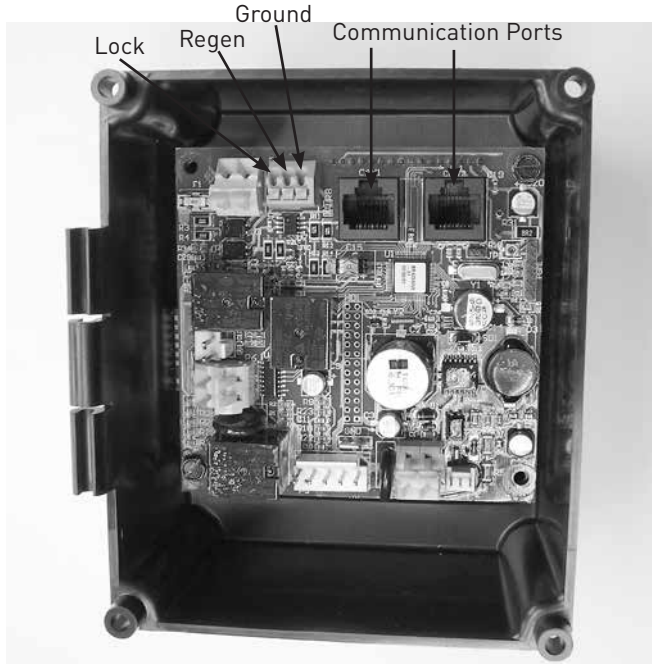

Figure 2 NXT Circuit Board

## MASTER PROGRAMMING MODE FLOW CHART

**CAUTION** Before entering Master Programming, please contact your local professional water dealer.

**NOTE:** Depending on current option settings, some displays cannot be viewed or set.

### Entering Master Programming Mode

1. Press and hold the Shift and Up buttons for 5 seconds. Press the Extra Cycle button once per display until all displays are viewed and Normal Display is resumed. Option setting displays may be changed as required by pressing either Up or Down button. Use the Shift button to move one space to the left.
2. Depending on current valve programming, certain displays may not be viewed or set.

**NOTE:** If the "D" button is pressed while in master programming, no changes will be saved.

### Exiting Master Programming Mode

1. Press the Extra Cycle button once per display until all are viewed. Master Programming Mode is exited and the normal display screen appears.
2. To exit the Master Programming Mode without saving changes, press the Diagnostic button.

**NOTE:** If no keypad activity is made for 5 minutes while in the Master Programming Mode, or if there is a power failure, no changes will be saved, and the unit will go back to the main display screen.

### Resets

**Soft Reset:** Press and hold the Up and Down buttons for 25 seconds until 12:00PM (or 12:00HR) appears. This resets all parameters except for the flow meter totalizer volume.

**Master Reset:** Hold the Extra Cycle button while powering up the unit. This resets all of the parameters in the unit. Check and verify the choices selected in Master Programming Mode.

**NOTE:** If the "D" button is pressed while in master programming, no changes will be saved.

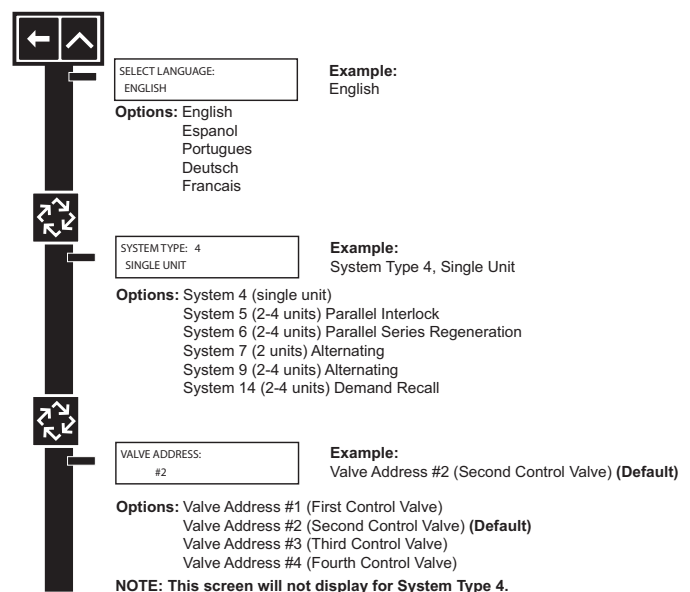



# MASTER PROGRAMMING MODE FLOW CHART *continued*

**SYSTEM SIZE:**  
2 VALVES  
**Example:**  
2 Valves in the System (Default)

**Options:** 2 Valves in the System (Default)  
3 Valves in the System  
4 Valves in the System

**Range:** 2 to 4 Valves in the System

**NOTE:** This screen will not display for System Type 4.

---

**REGEN TYPE:**  
TIME CLK DELAYED  
**Example:**  
Time Clock Delayed (Default)

**Options:** Time Clock Delayed (System 4 Only) (Default)  
Meter Immediate (All System Types)  
Meter Delayed Fixed Reserve (Systems 4 & 6 Only)

---

**VALVE TYPE:**  
2750  
**Example:**  
2750 (Default)

**Options:** 2750 (Default)  
2815  
2850  
2900  
3150  
3900  
Stager - Notch Cam

---

**REGENERANT FLOW:**  
DOWNFLOW  
**Example:**  
Downflow (Default)

**Options:** Downflow (Default)  
Up Flow  
UF Fill First

---

**REMOTE SIGNAL START:** 00:06:00  
**Example:**  
00:06:00 (Hours:Minutes:Seconds)

**Options:** Off (Default)  
00:00:00 (Hours:Minutes:Seconds)

**Range:** 1 second to 99 minutes (1 hour, 39 minutes)

**NOTE:** This display will not be viewed in System 4

---

**DISPLAY FORMAT:**  
US-GALLONS  
**Example:**  
U.S. Gallons (Default)

**Options:** U.S. - Gallons (Default)  
Eu Metric - Liters (Metric)

**NOTE:** In U.S. - Gallons mode, the display will be in 12-hour time.  
**NOTE:** In European Units - Liters (Metric) mode, the display will be in 24-hour time.

---

**UNIT CAPACITY:**  
00000000 GRAINS  
**Example:**  
Grains (Default)

**Options:** Grains (in U.S. Format) (Default)  
Grams (in Metric Format)

**Range:** 1 to 9,900,000 Grain Capacity in U.S. Format  
1 to 198,000 grams CaCO<sub>3</sub>/L Capacity in Metric Format

**NOTE:** Use the Shift button to move to the left.

---

**CAPACITY SAFETY FACTOR:** 00%  
**Example:**  
00% (Default)

**Range:** 0 to 50%

**NOTE:** Use the Shift button to move to the left.

---

**FEED WATER HARDNESS:** 15 GPG  
**Example:**  
15 GPG (U.S. Format) (Default)

**Range:** 1 to 199 Grains/Gallon (U.S. Format)  
20 to 1,999 milligrams CaCO<sub>3</sub>/L (Metric Format)

**NOTE:** Use the Shift button to move to the left.  
**NOTE:** This screen will only display on the lead unit for System Types 6 & 7. For all other System Types, it will display for all units.

## Trip Points 1, 2, and 3 (System 14 only)

This program step selects up to three Trip Points programmed on the master timer only (Valve Address #1).

The actual required number of Trip Points in a system is one less than the number of valves in the system.

Trip Point 1 represents the system flow rate at which a second valve will be brought In Service or Standby.

Trip Point 2 represents the system flow rate at which a third valve will be brought In Service or Standby.

Trip Point 3 represents the system flow rate at which a fourth valve will be brought In Service or Standby.

Trip Point 1	Trip Point 2	Trip Point 3
Range: 1 - 997 GPM	U.S.: Value of Trip Point 1 plus 1 to 998	U.S.: Trip Point 2 plus 1 to 999
Range: 0001 - 3997 Lpm	Metric: Value of Trip Point 1 plus 1 - 3998	Metric: Trip Point 2 plus 1 - 3999

## Trip Delays 1, 2, and 3 (System 14 only)

This program step selects each Trip Delay time that is addressed with each Trip Point and will be programmed on the Master timer only (Valve Address #1). The Trip Delay time represents a minimum amount of time the system flow rate is required to be equal or greater than the Trip Points to bring a unit In Service. It also is the minimum amount of time the system flow rate is required to be less than the Trip Points to remove a unit from In Service to Standby.

Trip Delay 1	Trip Delay 2	Trip Delay 3
Default: 30 Seconds		
Range: 30 - 99 Seconds	Range: 30 - 99 Seconds	Range: 30 - 99 Seconds

**TRIP POINT 1:**  
000 gpm

**Examples:** Default will need to be changed before next step [000] = (Default)  
Brings 2nd valve In Service after 125 gpm [125]  
Brings 2nd valve In Service after 400 lpm [400]

**Range:** 1 to 997 gpm (U.S. Format)  
0.01 to 3997 lpm (Metric Format)

**NOTE:** Display will not appear unless timer is programmed as valve position #1. Use the Shift button to change each decimal position.

---

**TRIP DELAY 1:**  
30 SECONDS

**Example:** Trip point time delay until valve goes into service [30] = Default  
**Range:** 30 to 99 seconds

**NOTE:** Display will not appear unless timer is programmed as valve position #1. Use the Shift button to move one space to the left.

---

**TRIP POINT 2:**  
gpm

**Examples:** Brings 3rd valve In Service after 250 gpm [250]  
Brings 3rd valve In Service after 900 lpm [900]

**Range:** Trip Point 1 + 1 to 998 gpm (U.S. Format)  
Trip Point 1 + 1 to 3998 lpm (Metric Format)

**NOTE:** Display will not appear unless timer is programmed as valve position #1. System size must be 3 or 4 to appear. Use the Shift button to move one space to the left.

---

**TRIP DELAY 2:**  
30 SECONDS

**Example:** Trip point time delay until valve goes into Service [30] = Default  
**Range:** 30 to 99 seconds

**NOTE:** Display will not appear unless timer is programmed as valve position #1. System size must be 3 or 4 to appear. Use the Shift button to move one space to the left.

# MASTER PROGRAMMING MODE

## FLOW CHART *continued*

**TRIP POINT 3:**

**Examples:** Brings 4th valve In Service after 350 gpm [350]  
 Brings 4th valve In Service after 1300 lpm [1300]

**Range:** Trip Point 2 + 1 to 999 gpm (U.S. Format)  
 Trip Point 2 + 1 to 3999 lpm (Metric Format)

**NOTE:** Display will not appear unless timer is programmed as valve position #1. System size must be 4 to appear. Use the Shift button to move one space to the left.

---

**TRIP DELAY 3:**

**Example:** Trip point time delay until valve goes to Service [30] = Default

**Range:** 30 to 99 seconds

**NOTE:** Display will not appear unless timer is programmed as valve position #1. System size must be 4 to appear. Use the Shift button to move one space to the left.

---

**REGENERATION DAY OVERRIDE:**

**Example:** Off (Default)  
 On (Default for time clock)

**REGENERATION DAY OVERRIDE:**

**Example:** 1 Day

**Options:** Off (Default for meter) or On

**Range:** 1 to 99 Days

---

**REGENERATION TIME:**

**Example:** 2:00 A.M. (Default)

**Options:** A.M. (U.S. Format)  
 HR (Metric Format)

**NOTE:** Regeneration time will not appear unless Regeneration Day Override is on.

### Regeneration Cycle Steps

This step programs the Regeneration Cycle step times 1 through 5. Please Refer to the chart below for regenerant flow default cycle steps and times.

Regenerant Flow	Cycle 1	Time	Cycle 2	Time
Downflow	Backwash	10 Minutes	Brine & Slow Rinse	1 Hour
UF Brine Draw	Brine & Slow Rinse	1 Hour	Backwash	10 Minutes
UF Fill First	Brine Tank Fill	12 Minutes	Brine Making	1 Hour

Regenerant Flow	Cycle 3	Time	Cycle 4	Time
Downflow	Rapid Rinse	10 Minutes	Brine Tank Fill	12 Minutes
UF Brine Draw	Rapid Rinse	10 Minutes	Brine Tank Fill	12 Minutes
UF Fill First	Brine & Slow Rinse	1 Hour	Backwash	10 Minutes

Regenerant Flow	Cycle 5	Time
Downflow	Pause	N/A
UF Brine Draw	Pause	N/A
UF Fill First	Rapid Rinse	10 Minutes

**CYCLE 1 00:00:00**

**Example:** Cycle 1 in Back Wash Mode

**Options:** Regeneration Cycle Step #1  
 Regeneration Cycle Step #2  
 Regeneration Cycle Step #3  
 Regeneration Cycle Step #4  
 Regeneration Cycle Step #5

**NOTE:** Please refer to the "Regenerant Flow Default Cycle Steps & Times" in the Master Programming Mode section of the manual.

**NOTE:** If Stager is chosen for Valve Type, the Regeneration Cycle Step description will not display.

---

**AUXILIARY RELAY:**

**Example:** Auxiliary Relay is Disabled

**Options:** Enabled  
 Disabled (Default)

---

**AUX RELAY OUTPUT**

**Example:** Auxiliary Relay Output in Start 1 at 0 hours, 0 minutes, & 0 seconds

**Range:** 00:00:00 to 18:00:00

**NOTE:** Only displayed if Auxiliary Relay is enabled in previous screen. Auxiliary Relay will only display if Chemical Pump is OFF for System Types 6 & 7.

---

**AUX RELAY OUTPUT**

**Example:** Auxiliary Relay Output in End 1 at 0 hours, 0 minutes, & 0 seconds

**Range:** 00:00:00 to 18:00:00

---

**CHEMICAL PUMP:**

**Example:** Chemical Pump is Disabled

**Options:** Enabled  
 Disabled (Default)

**NOTE:** This screen will only display on the lead unit for System Types 6 & 7. For all other System Types, it will display for all units.

---

**CPO AUX RELAY**

**Example:** Energize Chemical Pump Relay Every 50 Gallons  
 Energize Chemical Pump Relay Every 200 L

**Range:** 1 to 999 gallons in U.S. Format  
 1 to 9999 L in Metric Format

**NOTE:** Only displayed on units that physically have a meter (Lead always has a meter). Only shown if Auxiliary Relay is disabled on System Types 6 & 7.

---

**CPO AUX RELAY**

**Example:** Each Time the Chemical Pump Relay is on, Run for 30 Seconds (00:00:30)

**Range:** 00:00:00 to 02:00:00

---

**FLOW METER:**

**Example:** 1.0 Paddle Flow Meter

**Options:** 1.0 Paddle (Fleck)  
 1.0 Turbine (Fleck)  
 1.5 Paddle (Fleck)  
 1.5 Turbine (Fleck)  
 2.0 Paddle (Fleck)  
 3.0 Paddle (Fleck)  
 Generic (Non-Fleck)

**NOTES:** Default flow meter type is based on the valve type. This screen will only display on the lead unit for System Types 6 & 7. All other system types it will display for all units.

---

**MAXIMUM FLOW RATE:**

**Example:** Maximum Flow Rate of 0 gpm

**Range:** 20 - 2000 gpm (U.S. Format)  
 20 - 2000 L (Metric Format)

**NOTE:** Only displayed if "Generic" is chosen for the flow meter.

# MASTER PROGRAMMING MODE FLOW CHART *continued*

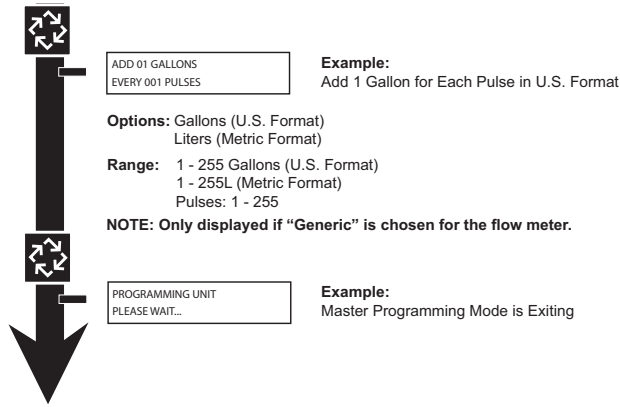

# USER PROGRAMMING MODE FLOW CHART

## Entering User Programming Mode

Hold the Set Up and Set Down buttons for 5 seconds.

**NOTE:** User Mode is only displayed when a metered option is chosen under System Type. Depending on current option settings, some displays cannot be viewed or set.

**NOTE:** User Mode cannot be entered on the Lag unit for System 6.

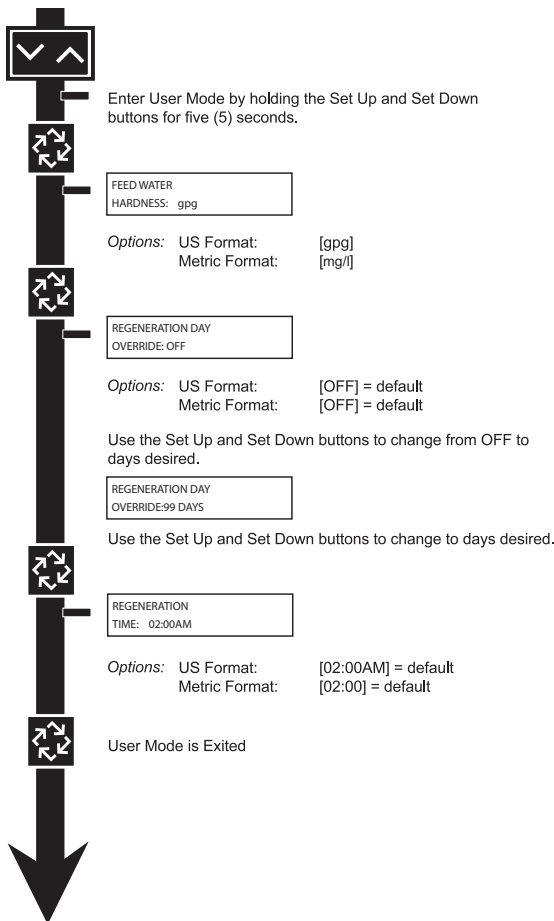

# DIAGNOSTIC PROGRAMMING MODE FLOW CHART

## Entering Diagnostic Programming Mode

1. Push and release the "D" button.
2. Press the Extra Cycle button once per display until all displays are viewed and Normal Display is resumed.
3. Push and release the "D" button at anytime during diagnostic mode and the timer will exit the mode.
4. Depending on the current controller programming, certain displays may not be able to be viewed or set.

## Overview Diagnostic Mode

The current diagnostic will be displayed until Extra Cycle key is pressed. There is no time limit on each display. The timer will display local information, not system information. In the event of a regeneration occurring while displaying diagnostics, the regeneration step and time remaining will be displayed. When regeneration has been completed, the display will return to the main screen.

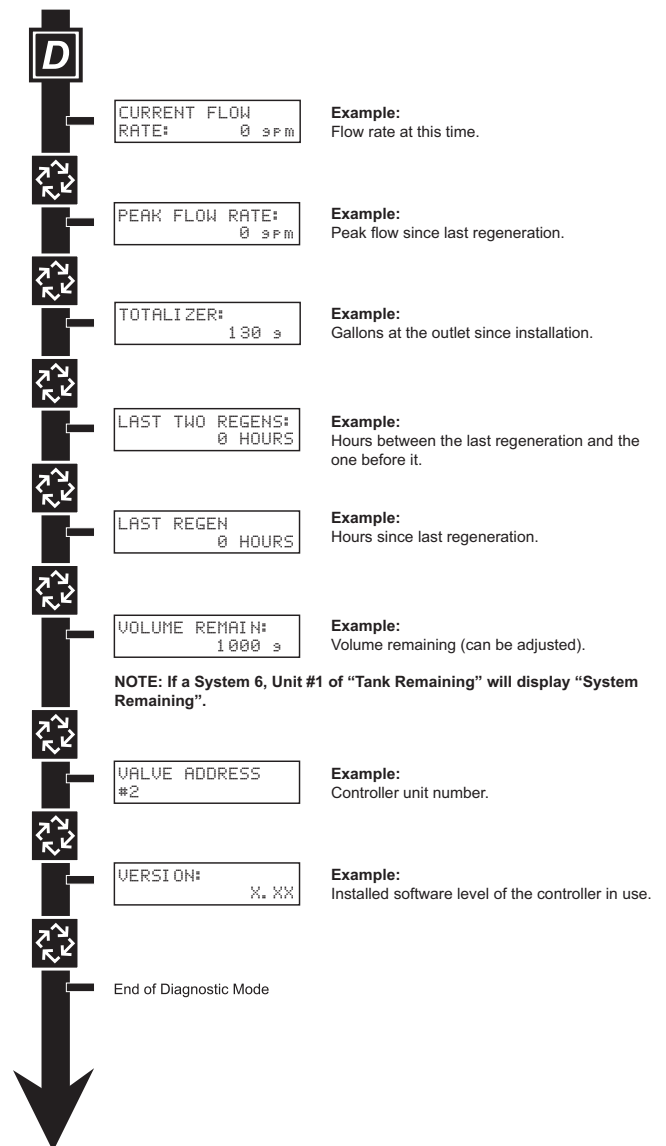

# NXT Multi Language Programming Parameters and Ranges

System Type	4 Time Clock				4 Metered Immediate				4 Metered Delayed				5 Interlock				6 Series				7 Alternating				9 Alternating				14 Demand Recall				Programming Parameter Ranges			
	1	2	3	4	1	2	3	4	1	2	3	4	1	2	3	4	1	2	3	4	1	2	3	4	1	2	3	4	1	2	3	4	Gallons	Liters		
Valve Address																																				
Select Language	x				x				x				x				x				x				x				English, Espanol, Portugues, Deutsch, Francals	1 thru 4						
System Size																																				
Regen Type	x				x				x				x				x				x				x											
Valve Type	x				x				x				x				x				x				x				Time Clock, Metered Delayed, Metered Immediate							
Regenerant Flow	x				x				x				x				x				x				x				2750, 2815, 2850, 2900, 3150, 3900, Stager							
Remote Signal Start	x				x				x				x				x				x				x				Downflow, Upflow, Upflow Fill First							
Display Format	x				x				x				x				x				x				x				Off, 00:00:01 - 01:39:00							
Unit Capacity																													US - Gallons	EU - Metric-Liters						
Capacity Safety Factor																													1 - 9900000 Grains	1 - 198000 gCaCO3						
Feed Water Hardness																													0 - 50%							
Trip Point 1																													1 - 199 Grains/Gallons	1 - 1999 mg/L						
Trip Delay 1																													0 - 997gpm	0 - 3997 Lpm						
Trip Point 2																													30 - 99 Seconds	30 - 99 Seconds						
Trip Delay 2																													Trip Point 1 + 1 - 998 gpm	Trip Point 1 + 1 - 3998 Lpm						
Trip Point 3																													30 - 99 Seconds	30 - 99 Seconds						
Trip Delay 3																													Trip Point 2 + 1 - 999 gpm	Trip Point 2 + 1 - 3999 Lpm						
Regeneration Day Override	x				x				x				x				x				x				x				30 - 99 Seconds	30 - 99 Seconds						
Regeneration Time	x				x				x				x				x				x				x				Off, 1 - 99							
Cycle 1	x				x				x				x				x				x				x				12:00 a.m. - 11:59 p.m.	00:00 - 23:59 Hour						
Cycle 2	x				x				x				x				x				x				x				00:00:00 - 04:00:00	00:00:00 - 04:00:00						
Cycle 3	x				x				x				x				x				x				x				Off, 00:00:00 - 04:00:00	Off, 00:00:00 - 04:00:00						
Cycle 4	x				x				x				x				x				x				x				Off, 00:00:00 - 04:00:00	Off, 00:00:00 - 04:00:00						
Cycle 5	x				x				x				x				x				x				x				Off, 00:00:00 - 04:00:00	Off, 00:00:00 - 04:00:00						
Auxiliary Relay	x				x				x				x				x				x				x				Enabled, Disabled	Enabled, Disabled						
Aux Relay Output Start	c				c				c				c				c				c				c				00:00:01 to Total Regeneration Time - 1	00:00:01 to Total Regeneration Time - 1						
Aux Relay Output End	c				c				c				c				c				c				c				Start Time + 1 to Total Regeneration Time	Start Time + 1 to Total Regeneration Time						
Chemical Pump																													Enabled, Disabled	Enabled, Disabled						
CPO Aux Relay Volume	c				c				c				c				c				c				c				1 - 999 gallons	0001 - 9999 Liters						
CPO Aux Relay Time	c				c				c				c				c				c				c				00:00:01 - 02:00:00	00:00:01 - 02:00:00						
Flow Meter																													1" 1.5" Paddle or Turbine, 2" Paddle, 3" Paddle, Generic							
Generic																																				
Maximum Flow Rate																													20 - 2000 GPM	20 - 2000 LPM						
Add ___ Gallons or Liters																													1 - 255 Gallons	001 - 255 Liters						
Every ___ Pulses																													1 - 255	1 - 255						

Notes

o - Regeneration Time will only be viewed if Regeneration Day Override is used.

u - If Auxiliary Relay is Enabled then Chemical Pump Relay will not be viewed or if Chemical Pump Relay is Enabled then Auxiliary R elay will not be viewed.

c - All Relay Output parameters programming will be viewed if Enabled.

a - If Generic Flow Meter is chosen, then programming parameters will be viewed.

# 2750/2850/2900S UPPER & 2900S LOWER POWERHEAD ASSEMBLY

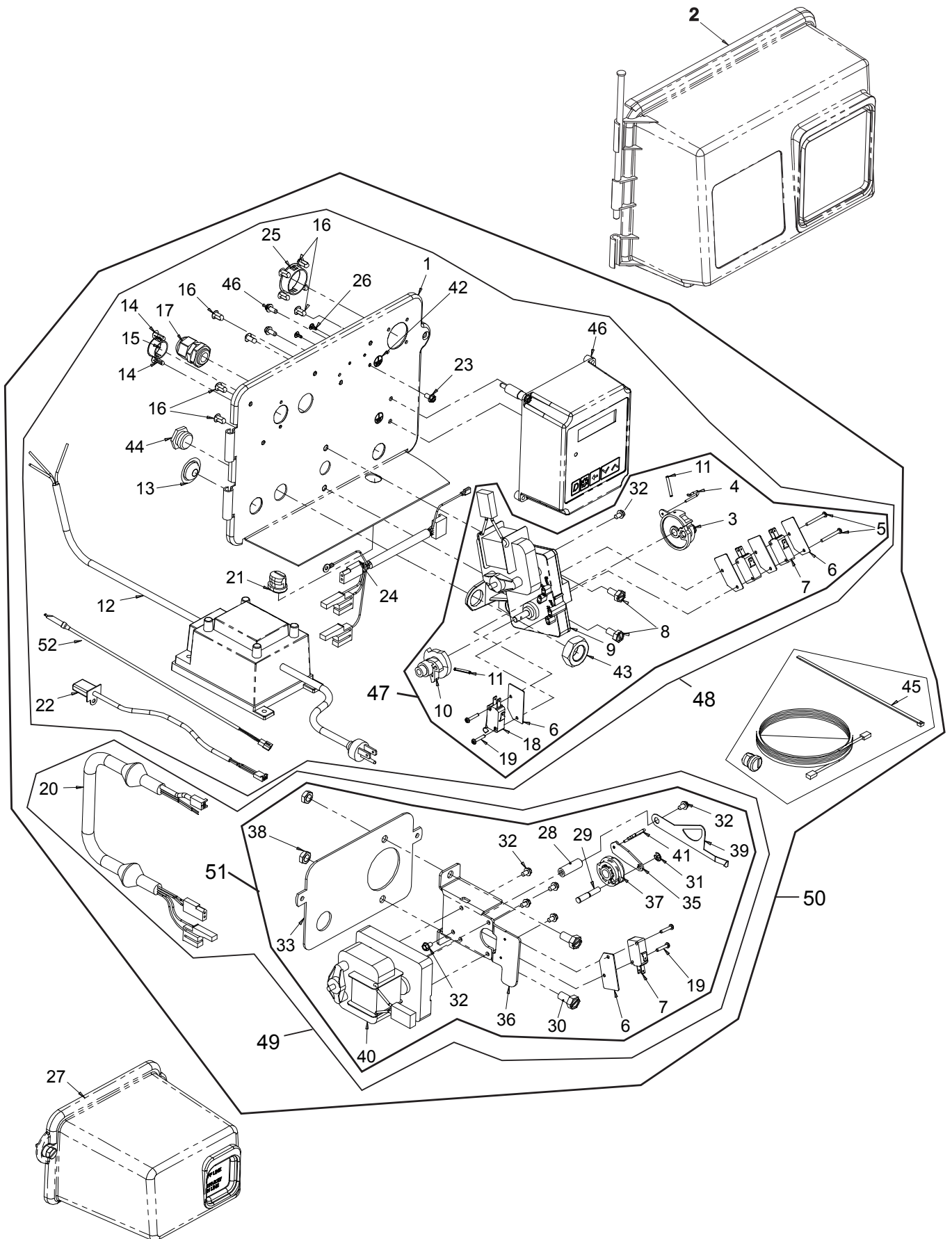

## 2750/2850/2900S UPPER & 2900S LOWER POWERHEAD ASSEMBLY *continued*

Item No.	QTY	Part No.	Description
1.....	1.....	18697-15.....	Backplate, Hinged
2.....	1.....	60219-02.....	Cover Assy, Environmental, Black
3.....	1.....	60160-15.....	Drive Cam Assy, Stf, Blue
4.....	1.....	10909.....	Pin, Link
5.....	2.....	14923.....	Screw, Pan Hd Mach, 4-40 X 1
6.....	5.....	10302.....	Insulator, Limit Switch
7.....	3.....	10218.....	Switch, Micro
8.....	2.....	10231.....	Screw, Slot Hex, 1/4 - 20 X 1/2
9.....	1.....	42579.....	Motor, Drive, 24V, 50/60 Hz
10.....	1.....	12777.....	Cam, Shut-Off Valve
11.....	2.....	10338.....	Pin, Roll, 3/32 X 7/8
12.....	1.....	42469.....	Transformer, Us, 120V, 24V, 40Va
		41049.....	Transformer, Euro, 230V/24V 108Va
		41050.....	Transformer, Aust, 230V/24V, 108Va
13.....	1.....	19691.....	Plug, .750 Dia, Recessed, Black
14.....	2.....	19800.....	Plug, .140 Dia, White
15.....	1.....	15806.....	Plug, Hole, Heyco #2693
16.....	9.....	19801.....	Plug, .190 Dia, White, Heyco #0307
17.....	1.....	17967.....	Fitting Assy, Liquid Tight, Blk
18.....	1.....	10896.....	Switch, Micro
19.....	4.....	11805.....	Screw, Rd Hd, 4-40 X 5/8 Type 1
20.....	1.....	40943.....	Wire Harness, Lower Drive, W/ Molded Strain Relief
21.....	1.....	13547.....	Strain Relief, Flat Cord, Heyco #30-1
22.....	1.....	19121.....	Meter Cable Assembly,
		19121-08.....	Meter Cable Assembly, 35 inch long with connector
		19121-09.....	Meter Cable Assembly, 100 inch long with connector
		19121-10.....	Meter Cable Assembly 304 inch long with connector
23.....	1.....	14202-01.....	Screw, Hex Wsh Mach, 8-32 X 5/16
24.....	1.....	40941.....	Wire Harness, Upper Drive
25.....	1.....	17421.....	Plug, 1.20 Hole, Heyco #2733
26.....	2.....	41581.....	Plug, Hole, .125 Dia, White
27.....	1.....	60217-02.....	Cover Assy, 2900, Lower, Black, Environmental
28.....	1.....	18626.....	Spacer, Indicator
29.....	1.....	18746.....	Bearing, Connecting Rod
30.....	2.....	11224.....	Screw, Hex Hd 5/16 - 18 X 5/8, Ss
31.....	1.....	10250.....	Ring, Retaining
32.....	7.....	10872.....	Screw, Hex Wsh, 8-32 X 17/64
33.....	1.....	18709.....	Backplate, Lower
34.....	1.....	11381.....	Pin, Roll, 2900/3900
35.....	1.....	14759.....	Link, Piston Rod
36.....	1.....	14769.....	Bracket, Motor, 2900
37.....	1.....	14775.....	Cam, Drive, 2900
38.....	2.....	16346.....	Nut, Hex, Jam, 5/16-18, 18-8-Ss
39.....	1.....	18725.....	Indicator, Service/Standby

Item No.	QTY	Part No.	Description
40.....	1.....	42580.....	Motor, Drive, 24V, 50/60 Hz, Sp
41.....	1.....	14813.....	Pin, Spring, Connecting Rod
42.....	1.....	41102.....	Label, 3200Nt, Ground
43.....	1.....	10269.....	Nut, Jam, 3/4 - 16
44.....	1.....	10712.....	Fitting, Brine Valve
45.....	1.....	61763.....	Kit, Can Communication Cable
46.....	1.....	42466-11.....	Timer Assy, Nxt, Right Hand
47.....		60050-23.....	Drive Assy, 2750, 2850, 2900S Upper, STF, 24V 50/60 Hz
		60050-26.....	Drive Assy, 2850S, STF, 24V 50/60 Hz
48.....	*		Powerhead Assy, 2750, 2850, 2900S Upper
	*		Powerhead Assy, 2850S
49.....	*		Powerhead Assy, Lower 2900S
50.....	*		Powerhead Assy, Upper and Lower 2900S
51.....		60055-53.....	Lower Drive Assy, 2900, 24/60
52.....	1.....	19791.....	Meter Cable Assembly,
		19791-02.....	Meter Cable Assembly, 28 inch long with connector
		19791-04.....	Meter Cable Assembly, 100 inch long with connector
		19791-05.....	Meter Cable Assembly 304 inch long with connector

\*Call you distributor for a Part Number

**NOTE: For all other service part numbers, see the Service Manual that accompanies the control valve.**



# 3150/3900 UPPER & LOWER POWERHEAD ASSEMBLY

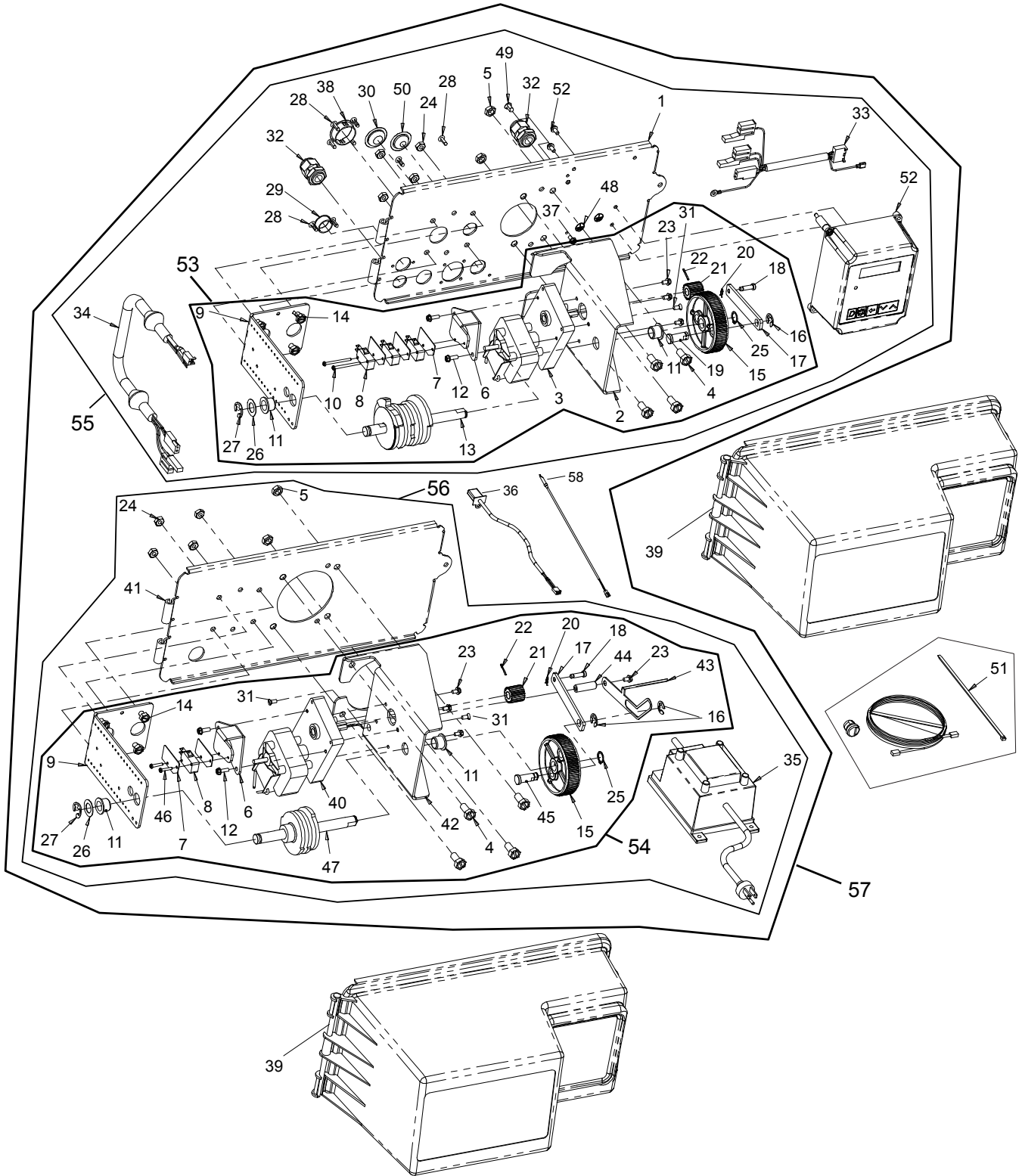

# 3150/3900 UPPER & LOWER POWERHEAD

## ASSEMBLY *continued*

Item No.	QTY	Part No.	Description
1.....	1.....	19304-04.....	Backplate, 3150/3900
2.....	1.....	15120.....	Bracket, Motor MTG, 3150/3900
3.....	1.....	42581.....	Motor, Drive, 24V, 50/60 Hz, SP
4.....	8.....	11224.....	Screw, Hex HD, 5/16 - 18 X 5/8, SS
5.....	4.....	16346.....	Nut, Hex, Jam, 5/16 - 18, 18-8-SS
6.....	2.....	17797.....	Bracket, Switch, Mounting, 3150/3900
7.....	5.....	10302.....	Insulator, Limit Switch
8.....	4.....	10218.....	Switch, Micro
9.....	2.....	16053.....	Bracket, Brine Side
10.....	2.....	12624.....	Screw, Phil Pan, 40 X 1 1/2
11.....	4.....	16052.....	Bushin, 3150/3900
12.....	4.....	17567.....	Screw, Hex, Wsh HD, 8 X 1/2
13.....	1.....	16494.....	Cam Assy, 3150/3900
14.....	8.....	10231.....	Screw, Slot Hex, 1/4 - 20 X 1/2 18-8 SS
15.....	2.....	16046.....	Gear, Drive
16.....	3.....	11774.....	Ring, Retaining
17.....	2.....	16047.....	Link, Drive
18.....	2.....	11709.....	Pin, Drive Link
19.....	1.....	16048.....	Bearing, Drive Link
20.....	2.....	11898.....	Clip, 3150/3900
21.....	2.....	16045.....	Pinion, Drive
22.....	2.....	11381.....	Pin, Roll, 2900/3900
23.....	7.....	10872.....	Screw, Hex Wsh, 8-32 X 17/64
24.....	8.....	11235.....	Nut, Hex, 1/4 - 20
25.....	2.....	16050.....	Ring, Retaining
26.....	2.....	16059.....	Washer, SS, .88, 3150/3900
27.....	2.....	16051.....	Ring, Retaining, Bowed
28.....	8.....	19800.....	Plug, .140, White
29.....	1.....	15806.....	Plug, Hole, Heyco, #2693
30.....	1.....	19591.....	Plug, .8750 Hole, Recessed, Black
31.....	3.....	11080.....	Screw, FLT HD Mach, 8-32 X 3/8
32.....	2.....	17967.....	Fitting Assy, Liquid Tight, Blk
33.....	1.....	40941.....	Wire Harness, Upper Drive
34.....	1.....	40943.....	Wire Harness, Lower Drive W/ Molded Strain Relief
35.....	1.....	42469.....	Transformer, US, 120V, 24V, 40VA
		41049.....	Transformer, Euro, 230V/24V 108VA
		41050.....	Transformer, Aust, 230V/24V, 108VA
36.....	1.....	19121.....	Meter Cable Assembly
		19121-08.....	Meter Cable Assembly, 35 inch long with connector
		19121-09.....	Meter Cable Assembly, 100 inch long with connector
		19121-10.....	Meter Cable Assembly, 304 inch long with connector

Item No.	QTY	Part No.	Description
37.....	1.....	14202-01.....	Screw, Hex Wsh, 8-32 X 5/16
38.....	1.....	17421.....	Plug, 1.20 Hole
39.....	2.....	60240-02.....	Cover Assy, 3150/3900, Env, Black
40.....	1.....	42581.....	Motor, Drive, 115V, 50/60Hz, SP
41.....	1.....	19305.....	Backplate, 3900, Lower, Env
42.....	1.....	16086.....	Bracket, Motor Mounting
43.....	1.....	19315.....	Indicator, Service/Standby, 3900
44.....	1.....	18726.....	Spacer, Indicator
45.....	1.....	16048.....	Bearing, Drive Link
46.....	2.....	11805.....	Screw, RD HD, 4-40 X 5/8, Type 1
47.....	1.....	16495.....	Cam Assy, 3900, Lower
48.....	1.....	41102.....	Label, 3200NT, Ground
49.....	1.....	19801.....	Plug, .190 Dia, White
50.....	1.....	19691.....	Plug, .750 Dia, Recessed, Black
51.....	1.....	61763.....	Kit, Can Communication Cable
52.....	1.....	42466-11.....	Timer Assy, Nxt, Right Hand
53.....		60057-03.....	Drive Assy, 3150, 3900 Upper, 24V 50/60 Hz
54.....		60058-03.....	Lower Drive Assy, 3900, 24V 50/60 Hz
55.....	*		Powerhead Assy, 3150, 3900 Upper
56.....	*		Powerhead Assy, 3900 Lower
57.....	*		Powerhead Assy, 3900 Upper & Lower
58.....	1.....	19791.....	Meter Cable Assembly
		19791-02.....	Meter Cable Assembly, 28 inch long with connector
		19791-04.....	Meter Cable Assembly, 100 inch long with connector
		19791-05.....	Meter Cable Assembly, 304 inch long with connector

\* Call your distributor for Part Number

**NOTE: For all other service part numbers, see the Service Manual that accompanies the control valve.**



# METER ASSEMBLY PLASTIC

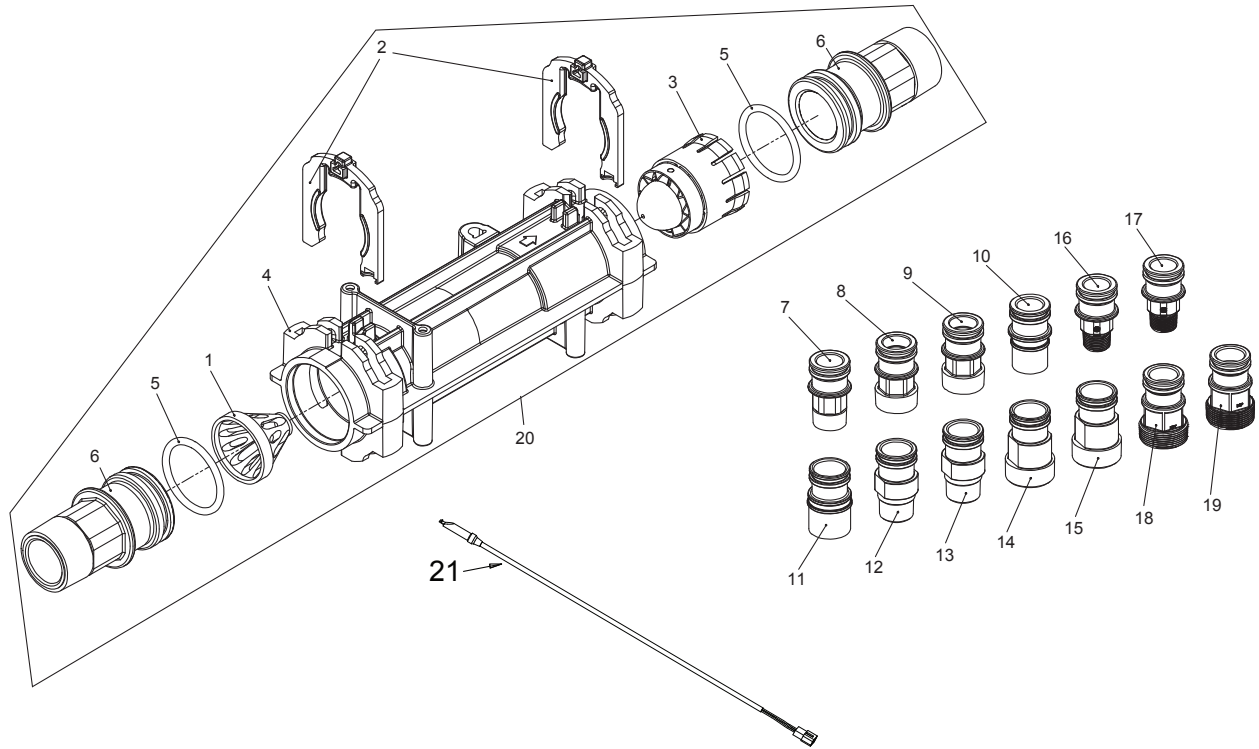

Item No.	QTY	Part No.	Description	Item No.	QTY	Part No.	Description
1	1	17542	Flow Straightener, 1-1/2"	20	1	61560	Meter Assy, 1-1/2" INLN, ELEC, PLAS, w/o Nipples, TURB
2	2	40576	Clip, H, Plastic, 7000			61560-01	Meter Assy, 1", INLN, NPT, ELEC, PLAS, PLAS Nipples, TURB
3	1	40577	Turbine Meter Assy, 7000			61560-02	Meter Assy, 1", INLN, BSP, ELEC, PLAS, PLAS Nipples, TURB
4	1	41555	Body, Inline Meter			61560-03	Meter Assy, 1-1/4" INLN, NPT, ELEC, PLAS, PLAS Nipples, TURB
5	2	40951	O-ring, -220			61560-04	Meter Assy, 1-1/4" INLN, BSP, ELEC, PLAS, PLAS Nipples, TURB
6	2	40563-01	Connector Assy, 1" NPT, Plastic, w/O-ring			61560-05	Meter Assy, 1" & 1-1/4", INLN, SWT, ELEC, PLAS, SWT Nipples, TURB
7	2	40563-11	Connector Assy, 1" BSP, Plastic, w/O-ring			61560-06	Meter Assy, 1-1/4" & 1-1/2", INLN, SWT, ELEC, PLAS, SWT Nipples, TURB
8	2	40565-01	Connector Assy, 1-1/4" NPT, Plastic, w/O-ring			61560-07	Meter Assy, 1" INLN, NPT, ELEC, PLAS, BRS Nipples, TURB
9	2	40565-11	Connector Assy, 1-1/4" BSP, Plastic, w/O-ring			61560-08	Meter Assy, 1" INLN, BSP, ELEC, PLAS, BRS Nipples, TURB
10	2	41242-01	Connector Assy, 1" & 1-1/4", Sweat, w/O-ring			61560-09	Meter Assy, 1-1/2" INLN, NPT, ELEC, PLAS, BRS Nipples, TURB
11	2	41243	Connector, 1-1/4" & 1-1/2" Sweat, 7000			61560-10	Meter Assy, 1-1/2" INLN, BSP, ELEC, PLAS, BRS Nipples, TURB
		41243-01	Connector Assy, 1-1/4" & 1-1/2", Sweat, w/O-ring			61560-11	Meter Assy, 3/4" INLN, NPT, ELEC, PLAS, PLAS Nipples, TURB
12	2	61561	Connector Assy, 1" NPT, Brass, w/O-ring			61560-12	Meter Assy, 3/4" INLN, BSP, ELEC, PLAS, PLAS Nipples, TURB
13	2	61561-10	Connector Assy, 1" BSP, Brass, w/O-ring			61560-13	Meter Assy, 1-1/2", INLN, NPT, ELEC, PLAS, PLAS Nipples, TURB
14	2	61562	Connector Assy, 1-1/2" NPT, Brass, w/O-ring			61560-14	Meter Assy, 1-1/2" INLN, BSP, ELEC, PLAS, PLAS Nipples, TURB
15	2	61562-10	Connector Assy, 1-1/2" BSP, Brass, w/O-ring	21	1	19791	Meter Cable Assembly,
16	2	42414-01	Connector 3/4" NPT, Plastic, w/O-ring			19791-02	Meter Cable Assembly, 28 inch long with connector
17	2	42414-11	Connector, Assy, 3/4" BSP, Plastic, w/O-ring			19791-04	Meter Cable Assembly, 100 inch long with connector
18	3	42241-01	Connector Assy, 1-1/2" NPT, Plastic, w/O-ring			19791-05	Meter Cable Assembly 304 inch long with connector
19	3	42241-11	Connector Assy, 1-1/2" BSP, Plastic, w/O-Ring				

# 1-INCH BRASS METER ASSEMBLY

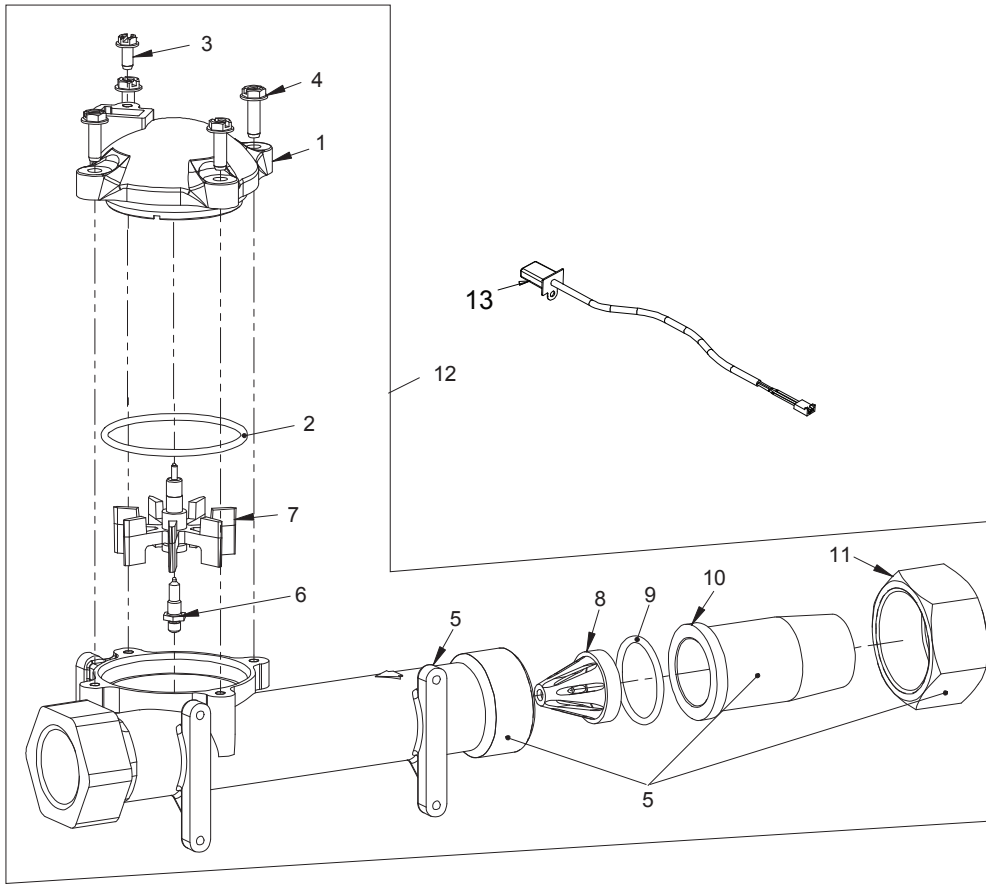

Item No.	QTY	Part No.	Description
1.....	1.....	14716 .....	Meter Cap Assy, Elec, Plastic Paddlewheel
2.....	1.....	13847 .....	O-ring, -137
3.....	1.....	17798 .....	Screw, Slot Hex WSH HD
4.....	4.....	12473 .....	Screw, Hex WSH, 10-24 x 5/8
5.....	1.....	14959-20.....	Body, Meter, 1", BSP, Metric, Brass
6.....	1.....	13882 .....	Post, Meter Impeller
7.....	1.....	13509 .....	Impeller, Meter
8.....	1.....	14960 .....	Flow Straightener, 1"
9.....	1.....	13287 .....	O-ring, 123
10.....	1.....	14961-10.....	Fitting, 1" Quick Connector, BSP
11.....	1.....	14962 .....	Nut, Quick Connect NPT
12.....	1.....	60613 .....	Meter Assy, 1" Inline, NPT, Electronic, Brass, PDL
		..... 60613NP .....	Meter Assy, 1" Inline, NPT, Electronic, Nickel, PDL
		..... 60613-20.....	Meter Assy, 1" Inline, BSP, Electronic, Brass, PDL
13.....	1.....	19121 .....	Meter Cable Assembly,
		..... 19121-08.....	Meter Cable Assembly, 35 inch long with connector
		..... 19121-09.....	Meter Cable Assembly, 100 inch long with connector
		..... 19121-10.....	Meter Cable Assembly 304 inch long with connector

# 1-INCH STAINLESS STEEL METER ASSEMBLY

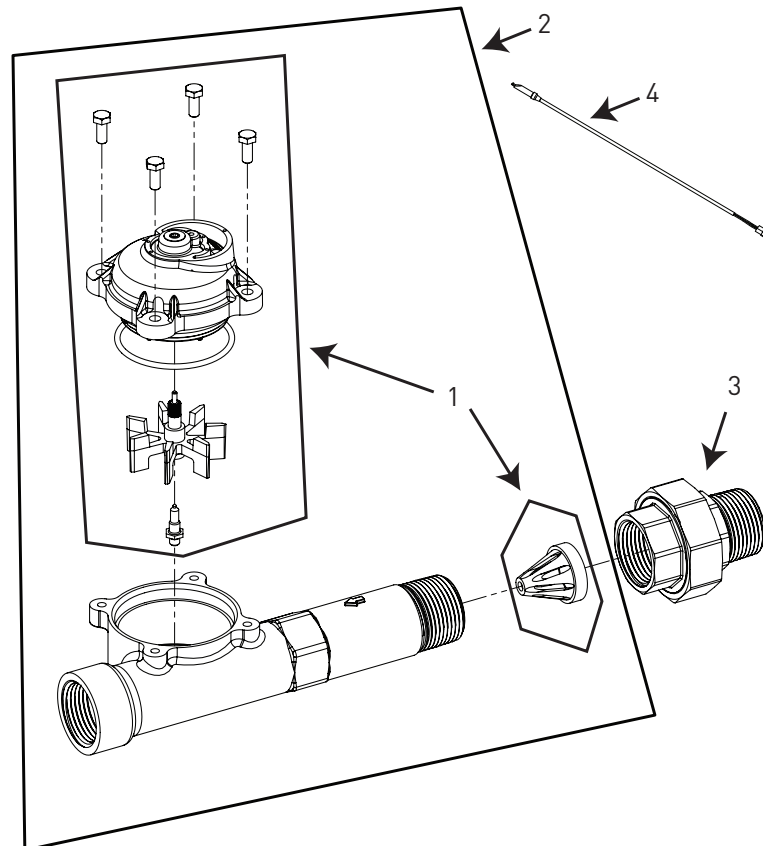

Item No.	QTY	Part No.	Description
1.....	1.....	62049-01.....	Service Kit, 1 inch & 1-1/2 inch Meter, Standard Range
	1.....	62049-02.....	Service Kit, 1 inch & 1-1/2 inch Meter, Extended Range
2.....	1.....	61932-10.....	Meter Assy, 1 inch, Inline, Stainless Steel, NPT, Standard Range
	1.....	61932-11.....	Meter Assy, 1 inch, Inline, Stainless Steel, NPT, Extended Range
	1.....	61932-20.....	Meter Assy, 1 inch, Inline, Stainless Steel, BSP, Standard Range
	1.....	61932-21.....	Meter Assy, 1 inch, Inline, Stainless Steel, BSP, Extended Range
3.....	1.....	44022.....	Union, 1 inch, NPT (Optional on models with electronic controls)
	1.....	44023.....	Union, 1 inch, BSP (Optional on models with electronic controls)
4.....	1.....	19791.....	Meter Cable Assembly,
		..... 19791-02.....	Meter Cable Assembly, 28 inch long with connector
		..... 19791-04.....	Meter Cable Assembly, 100 inch long with connector
		..... 19791-05.....	Meter Cable Assembly 304 inch long with connector

# 1-1/2 INCH BRASS METER ASSEMBLY

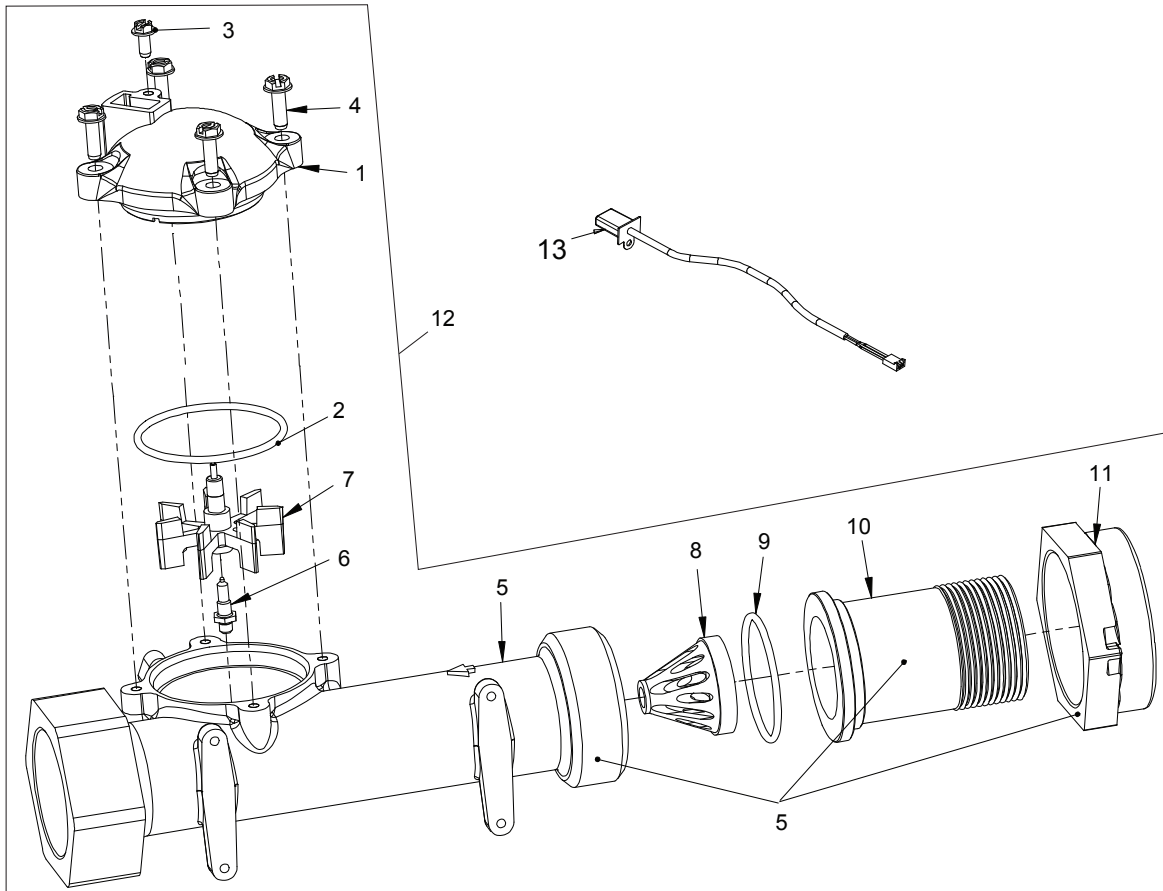

Item No.	QTY	Part No.	Description
1.....	1.....	14716 .....	Meter Cap Assy, Elec, Plastic Paddlewheel
2.....	1.....	13847 .....	O-ring, -137
3.....	1.....	17798 .....	Screw, Slot Hex WSH HD
4.....	4.....	12473 .....	Screw, Hex WSH, 10-24 x 5/8
5.....	1.....	17569-20.....	Body, Meter, BSP, 1-1/2" Quick Connector Brass
6.....	1.....	13882 .....	Post, Meter Impeller
7.....	1.....	13509 .....	Impeller, Meter
8.....	1.....	17542 .....	Flow Straightener, 1-1/2"
9.....	1.....	12733 .....	O-ring, -132
10.....	1.....	17544-10.....	Fitting, 1-1/2" Quick Connector, BSP
11.....	1.....	17543 .....	Nut, Quick Connect 1-1/2"
12.....	1.....	60614 .....	Meter Assy, 1-1/2" Inline, NPT, Electronic, Brass Body, PDL
		..... 60614NP .....	Meter Assy, 1-1/2" INLN, NPT, ELEC, BRS BDY, NP, PDL
		..... 60614-01.....	Meter Assy, 1-1/2" INLN, NPT, ELEC, BRS BDY, PDL, 1" SLV
		..... 60614-01NP.....	Meter Assy, 1-1/2" INLN, NPT, ELEC, BRS BDY, NP, PDL, 1" SLV
		..... 60614-20.....	Meter Assy, 1-1/2" INLN, BSP, ELEC, BRS BDY, PDL, 1" SLV
		..... 60614-20NP.....	Meter Assy, 1-1/2" INLN, BSP, ELEC, BRS BDY, NP, PDL, 1" SLV

Item No.	QTY	Part No.	Description
13.....	1.....	19121 .....	Meter Cable Assembly,
		..... 19121-08.....	Meter Cable Assembly, 35 inch long with connector
		..... 19121-09.....	Meter Cable Assembly, 100 inch long with connector
		..... 19121-10.....	Meter Cable Assembly 304 inch long with connector

# 1-1/2 INCH STAINLESS STEEL METER ASSEMBLY

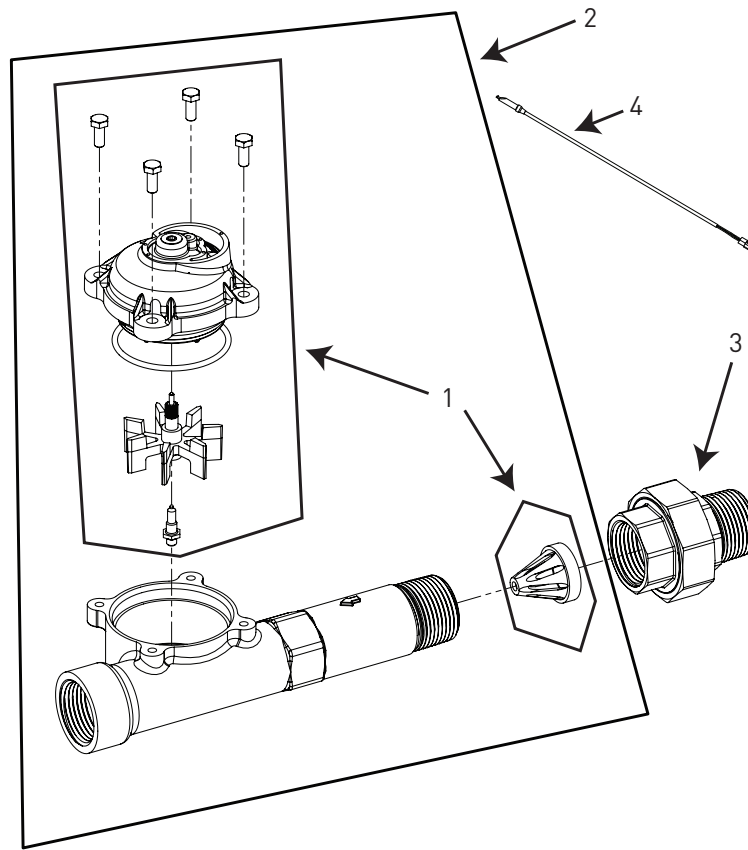

Item No.	QTY	Part No.	Description	Not Shown (optional)
1.....	1.....	62049-01.....	Service Kit, 1 inch & 1-1/2 inch Meter, Standard Range	1..... 62072 ..... Meter Sleeve, 1-1/2 inch to 1 inch (optional)
1.....	1.....	62049-02.....	Service Kit, 1 inch & 1-1/2 inch Meter, Extended Range	
2.....	1.....	61933-10.....	Meter Assy, 1-1/2 inch, Inline, Stainless Steel, NPT, Standard Range	
1.....	1.....	61933-11.....	Meter Assy, 1-1/2 inch, Inline, Stainless Steel, NPT, Extended Range	
1.....	1.....	61933-20.....	Meter Assy, 1-1/2 inch, Inline, Stainless Steel, BSP, Standard Range	
1.....	1.....	61933-21.....	Meter Assy, 1-1/2 inch, Inline, Stainless Steel, BSP, Extended Range	
3.....	1.....	44024.....	Union, 1-1/2 inch, NPT (Optional on models with electronic controls)	
1.....	1.....	44025.....	Union, 1-1/2 inch, BSP (Optional on models with electronic controls)	
4.....	1.....	19791.....	Meter Cable Assembly,	
		..... 19791-02.....	Meter Cable Assembly, 28 inch long with connector	
		..... 19791-04.....	Meter Cable Assembly, 100 inch long with connector	
		..... 19791-05.....	Meter Cable Assembly 304 inch long with connector	

## 2 INCH BRASS METER ASSEMBLY

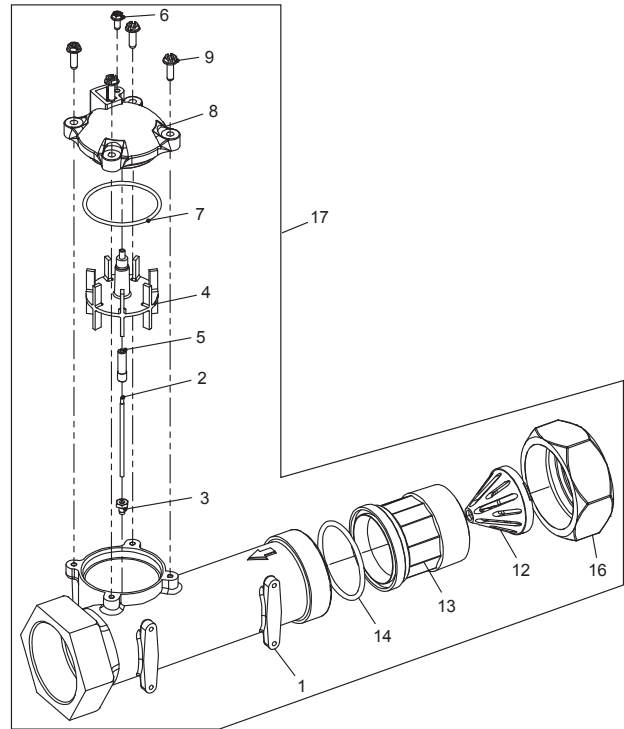
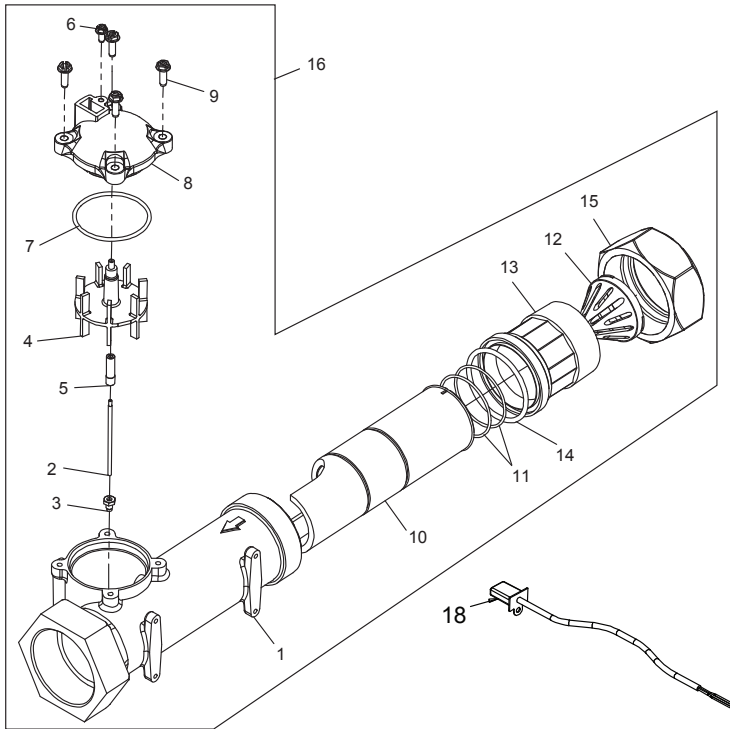

Item No.	QTY	Part No.	Description
1	1	14456	Body, Meter 2"
	1	14456-20	Body, Meter, 2", BSP, Metric
	1	14456-20NP	Body, Meter, 2", BSP, Metric, NP
2	1	15432	Shaft, Impeller, SS
3	1	15532	Seat, Impeller Shaft, Hex
4	1	15374-01	Impeller, 2" Meter
5	1	15381	Plug, Impeller 2" Meter
6	1	17798	Screw, Slot Hex WSH HD
7	1	13847	O-ring, -137
8		14716	Meter Cap Assy, ELEC, Plastic, Paddlewheel
9	4	12473	Screw, Hex WSH, 10-24 x 5/8
	4	21716	Screw, Hex Head, M5 x 16
10		61439	Meter Sleeve w/O-ring, MACHD
11	2	16080	O-ring, -032
12	1	14680	Flow Straightener
13	1	14568	Fitting, Nipple, 2"
	1	14568-10	Fitting, Nipple, 2", BSP, Brass
	1	14568-10NP	Fitting, Nipple, 2", BSP, Brass, NP
14	1	14679	O-ring, -227
15	1	14569	Nut, Quick Connect
16		60615	Meter Assy, 2" INLN, NPT, ELEC, BRS, PDL, 1.5" SLV
		60615NP	Meter Assy, 2" INLN, NPT, ELEC, NP, PDL, 1.5" SLV
		60615-20	Meter Assy, 2" INLN, BSP/MET, ELEC, BRS, PDL, 1.5" SLV
		60615-20NP	Meter Assy, 2" INLN, BSP/MET, ELEC, NP, PDL, 1.5" SLV

Item No.	QTY	Part No.	Description
17		60616	Meter Assy, 2" INLN, NPT, ELEC, BRS, PDL
		60616NP	Meter Assy, 2" INLN, NPT, ELEC, NP, PDL
		60616-20	Meter Assy, 2" INLN, BSP/MET, ELEC, BRS, PDL
		60616-20NP	Meter Assy, 2" INLN, BSP/MET, ELEC, NP, PDL
18	1	19121	Meter Cable Assembly,
		19121-08	Meter Cable Assembly, 35 inch long with connector
		19121-09	Meter Cable Assembly, 100 inch long with connector
		19121-10	Meter Cable Assembly 304 inch long with connector

## 2 INCH STAINLESS STEEL METER ASSEMBLY

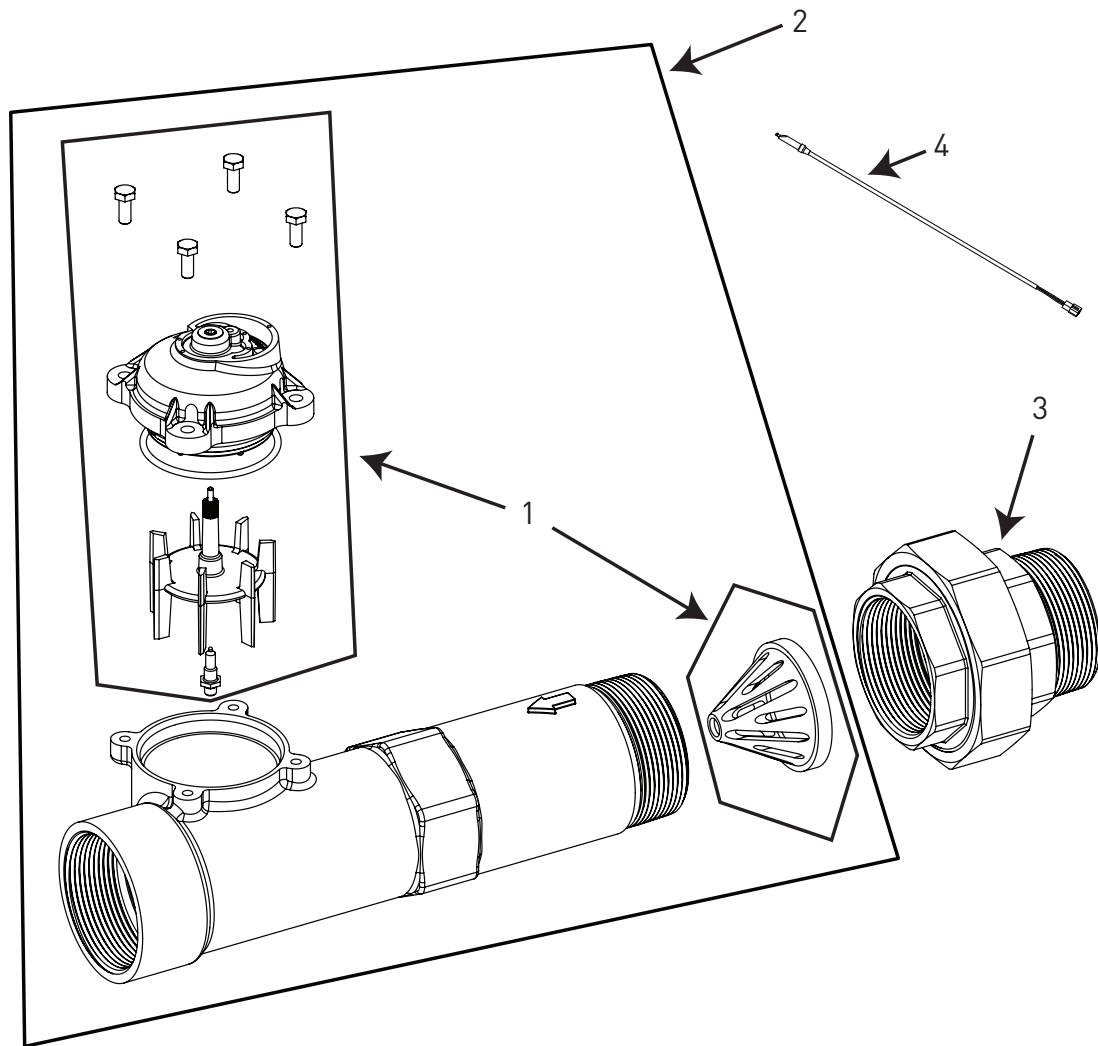

Item No.	QTY	Part No.	Description
1.....	1.....	62048-01.....	Service Kit, 2 inch Meter, Standard Range
	1.....	62048-02.....	Service Kit, 2 inch Meter, Extended Range
2.....	1.....	61934-10.....	Meter Assy, 2 inch, Inline, Stainless Steel, NPT, Standard Range
	1.....	61934-11.....	Meter Assy, 2 inch, Inline, Stainless Steel, NPT, Extended Range
	1.....	61934-20.....	Meter Assy, 2 inch, Inline, Stainless Steel, BSP, Standard Range
	1.....	61934-21.....	Meter Assy, 2 inch, Inline, Stainless Steel, BSP, Extended Range
3.....	1.....	44026.....	Union, 2 inch, NPT (Optional on models with electronic controls)
	1.....	44027.....	Union, 2 inch, BSP (Optional on models with electronic controls)

Item No.	QTY	Part No.	Description
4.....	1.....	19791.....	Meter Cable Assembly,
		19791-02.....	Meter Cable Assembly, 28 inch long with connector
		19791-04.....	Meter Cable Assembly, 100 inch long with connector
		19791-05.....	Meter Cable Assembly 304 inch long with connector

### Not Shown (optional)

1.....	62073.....	Meter Sleeve , 2 inch to 1-1/2 inch (optional)
--------	------------	--

# 3 INCH BRASS METER ASSEMBLY

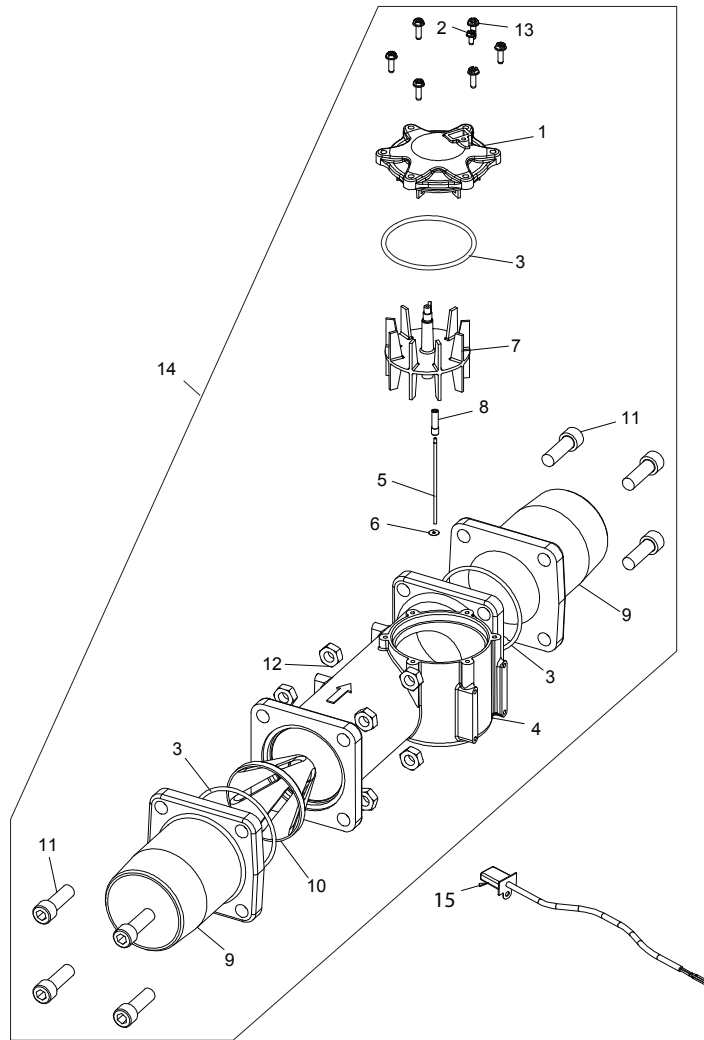

Item No.	QTY	Part No.	Description
1.....	1.....	14716-01.....	Meter Cap Assy, 3" ELEC, Plastic, Paddlewheel
2.....	1.....	17798.....	Screw, Hex Washer Head, #8-16 x 0.38
3.....	3.....	15707.....	O-ring, -236
4.....	1.....	16254-20.....	Body Meter, 3900, BSP
5.....	1.....	16279.....	Shaft, Impeller, SS
6.....	1.....	16574.....	Washer, Plain, SS
7.....	1.....	16252.....	Impeller, 3900
8.....	1.....	15381.....	Plug, Impeller, 2" Meter
9.....	2.....	16328-10.....	Adapter, Flange, 3" BSP
10.....	1.....	16280.....	Flow Straightener
11.....	8.....	40118.....	Screw, SCKT HD, 1/2-13 UN
12.....	8.....	16386.....	Nut, Hex, Jam, 1/2-13, 18-8 S.S.
13.....	6.....	12473.....	Screw, Hex Washer Head, #10-24 x 0.625
14.....		60617.....	Meter Assy, 3" INLN, NPT, Electronic, BRS BDY, Paddlewheel
		60617-10.....	Meter Assy, 3" INLN, BSP, Electronic, BRS BDY, Paddlewheel

Item No.	QTY	Part No.	Description
15.....	1.....	19121.....	Meter Cable Assembly,
		19121-08.....	Meter Cable Assembly, 35 inch long with connector
		19121-09.....	Meter Cable Assembly, 100 inch long with connector
		19121-10.....	Meter Cable Assembly 304 inch long with connector



# 3 INCH STAINLESS STEEL METER ASSEMBLY

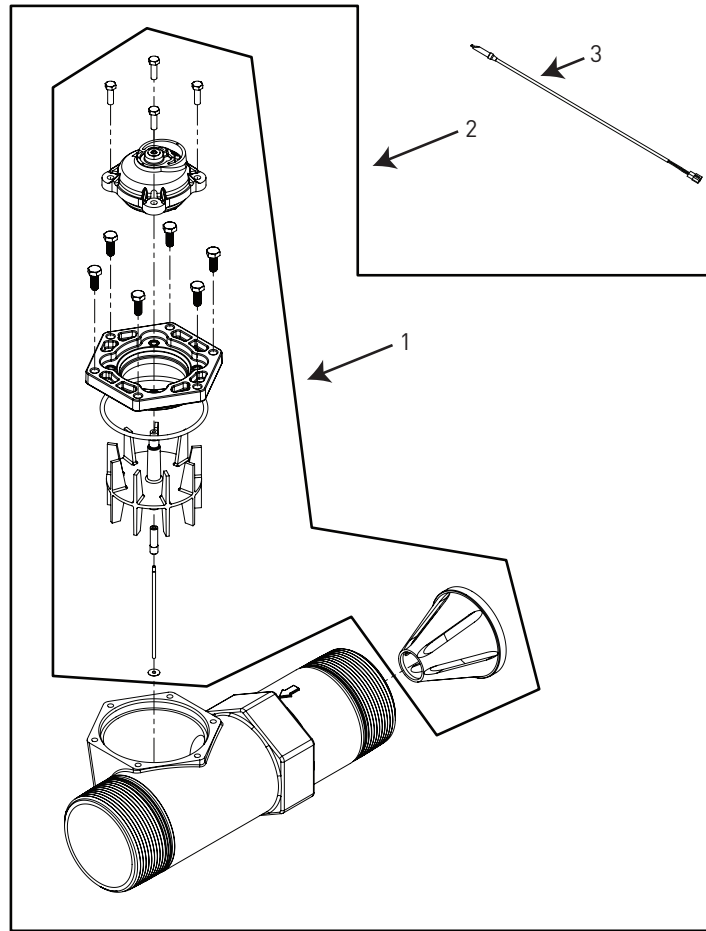

Item No.	QTY	Part No.	Description
1.....	1.....	62078-01.....	Service Kit, 3 Inch Meter, Standard Range
	1.....	62078-02.....	Service Kit, 3 Inch Meter, Extended Range
2.....	1.....	61935-10.....	Meter Assy, 3 Inch, Inline, Stainless Steel, NPT, Standard Range
		61935-11.....	Meter Assy, 3 Inch, Inline, Stainless Steel, NPT, Extended Range
		61935-20.....	Meter Assy, 3 Inch, Inline, Stainless Steel, BSP, Standard Range
		61935-21.....	Meter Assy, 3 Inch, Inline, Stainless Steel, BSP, Extended Range
3.....	1.....	19791.....	Meter Cable Assembly,
		19791-02.....	Meter Cable Assembly, 28 inch long with connector
		19791-04.....	Meter Cable Assembly, 100 inch long with connector
		19791-05.....	Meter Cable Assembly 304 inch long with connector

# SINGLE PISTON WIRING DIAGRAM

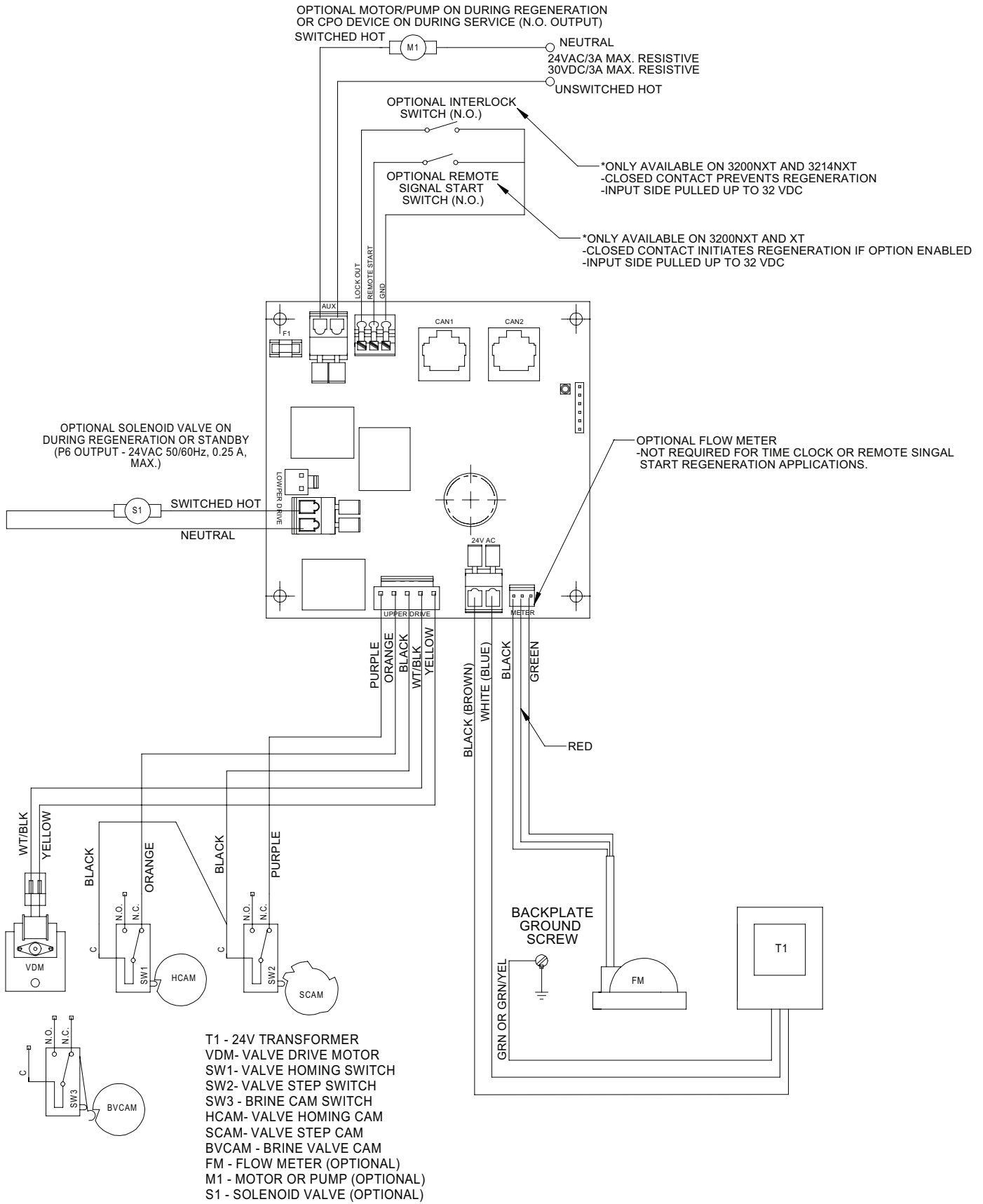

NOTE:  
VALVE SHOWN IN SERVICE

42140\_Rev D

# DUAL PISTON WIRING DIAGRAM

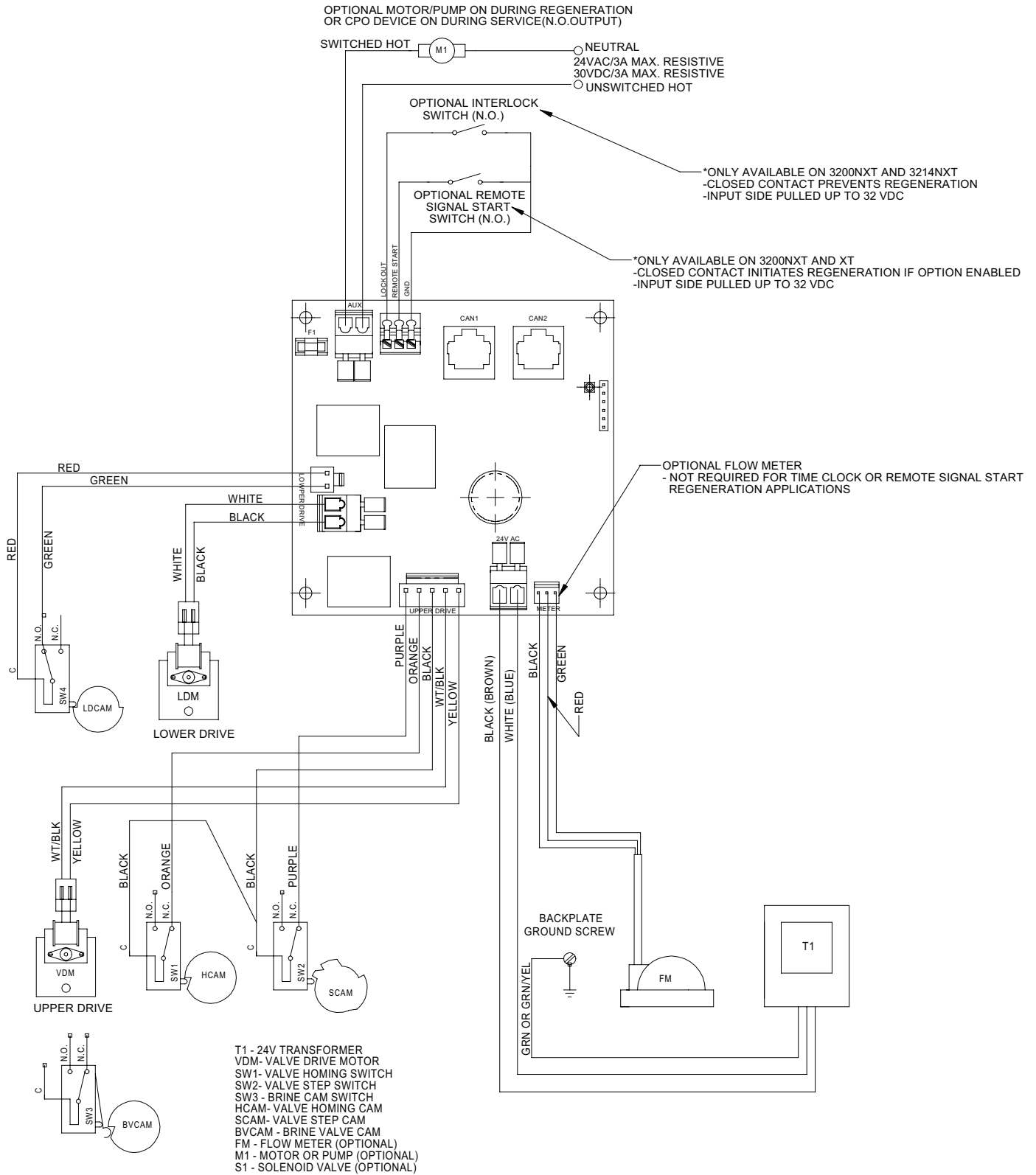

42140\_Rev C

# REMOTE TIMER WIRING DIAGRAM

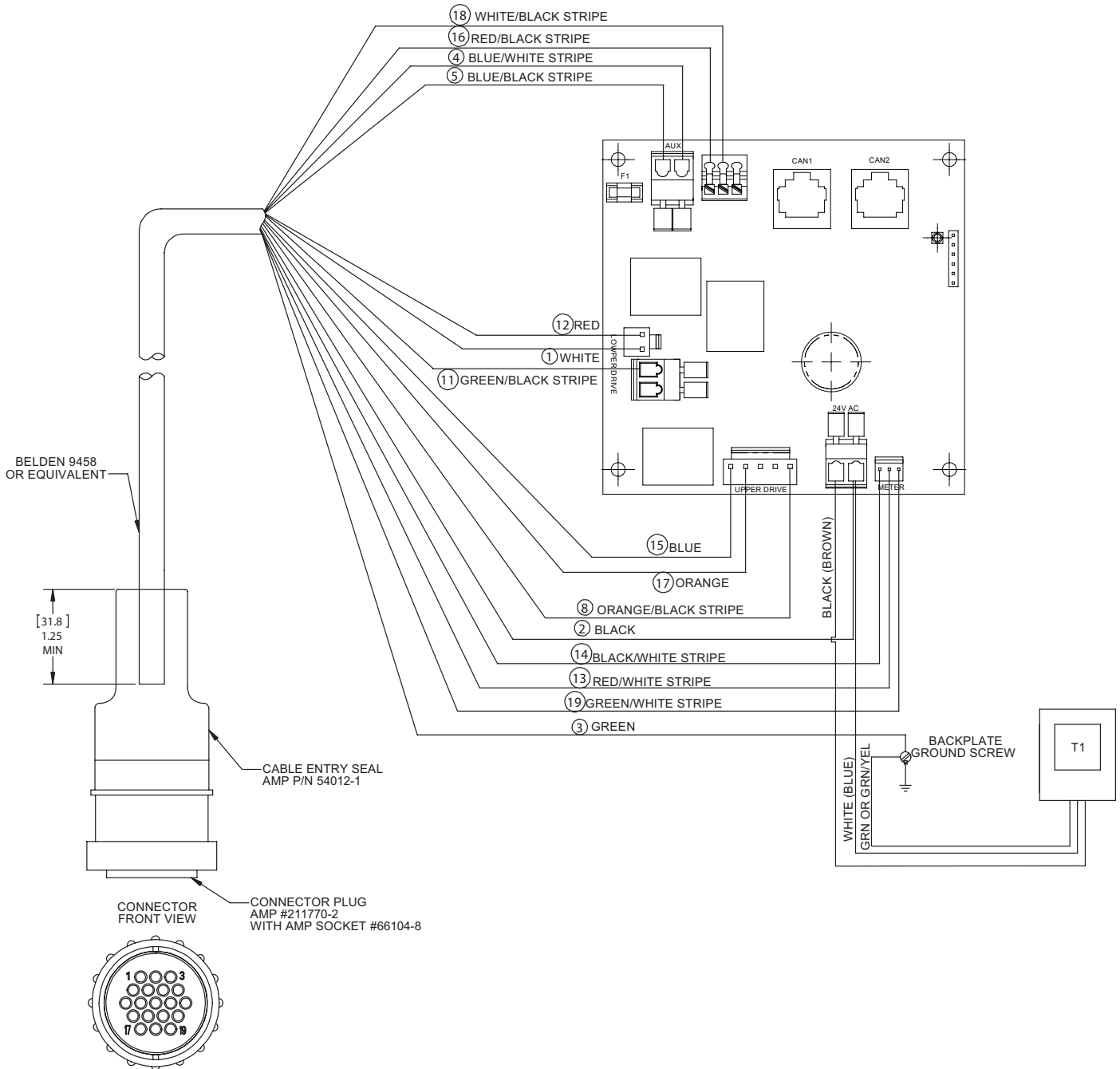

# 2750/2850 REMOTE TIMER WIRING DIAGRAM

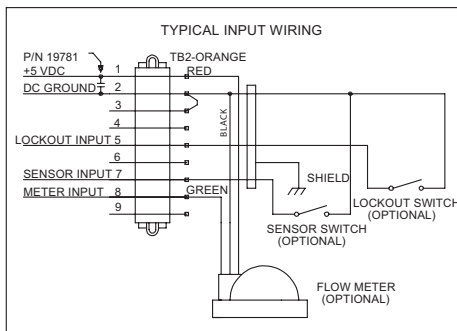
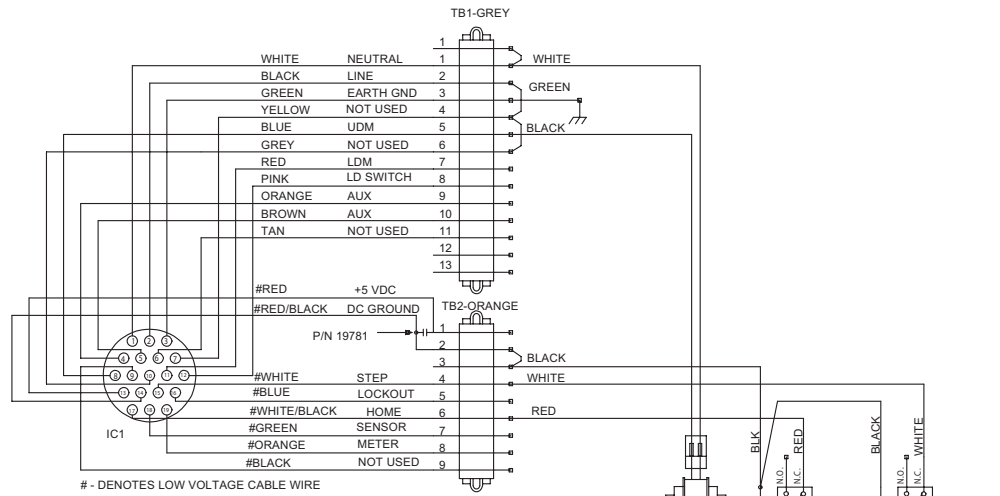
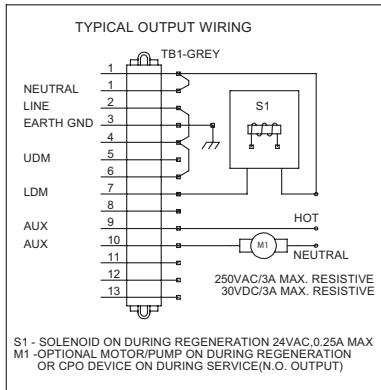

TB1 - HIGH VOLTAGE 14 POSITION TERMINAL BLOCK  
TB2 - LOW VOLTAGE 9 POSITION TERMINAL BLOCK  
IC1 - INTERLOCK CABLE RECEPTACLE  
UDM - UPPER DRIVE MOTOR  
LDM - LOWER DRIVE MOTOR  
AUX - AUXILIARY RELAY  
HCAM - VALVE HOMING CAM  
SCAM - VALVE STEP CAM  
SW1 - VALVE HOMING SWITCH  
SW2 - VALVE STEP SWITCH  
LD SWITCH - LOWER DRIVE SWITCH

NOTE:  
VALVE SHOWN IN SERVICE POSITION.

# 2900 REMOTE TIMER WIRING DIAGRAM

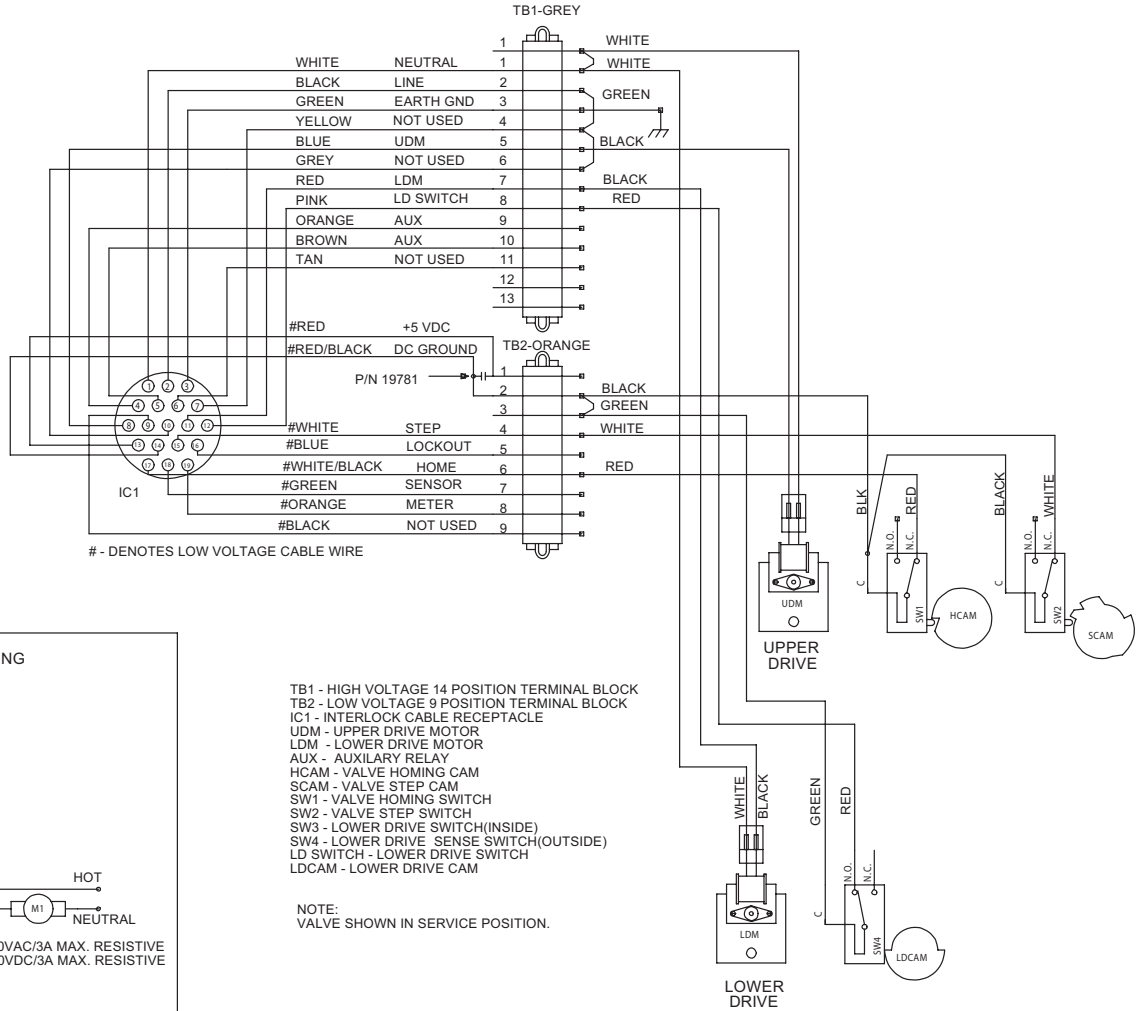

# - DENOTES LOW VOLTAGE CABLE WIRE

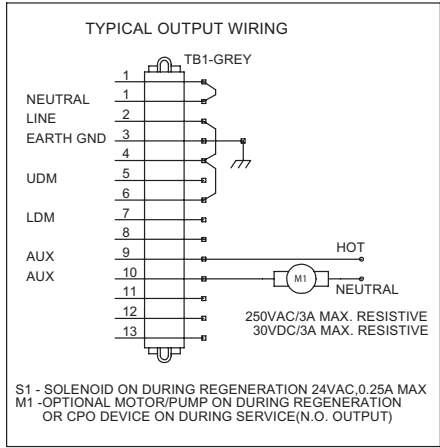

TB1 - HIGH VOLTAGE 14 POSITION TERMINAL BLOCK  
 TB2 - LOW VOLTAGE 9 POSITION TERMINAL BLOCK  
 IC1 - INTERLOCK CABLE RECEPTACLE  
 UDM - UPPER DRIVE MOTOR  
 LDM - LOWER DRIVE MOTOR  
 AUX - AUXILIARY RELAY  
 HCAM - VALVE HOMING CAM  
 SCAM - VALVE STEP CAM  
 SW1 - VALVE HOMING SWITCH  
 SW2 - VALVE STEP SWITCH  
 SW3 - LOWER DRIVE SWITCH (INSIDE)  
 SW4 - LOWER DRIVE SENSE SWITCH (OUTSIDE)  
 LD SWITCH - LOWER DRIVE SWITCH  
 LDCAM - LOWER DRIVE CAM

NOTE:  
 VALVE SHOWN IN SERVICE POSITION.

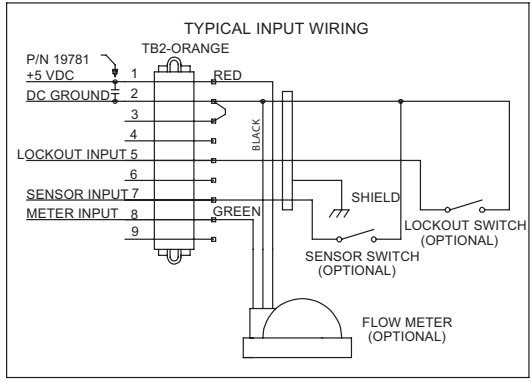

# 3900 REMOTE TIMER WIRING DIAGRAM

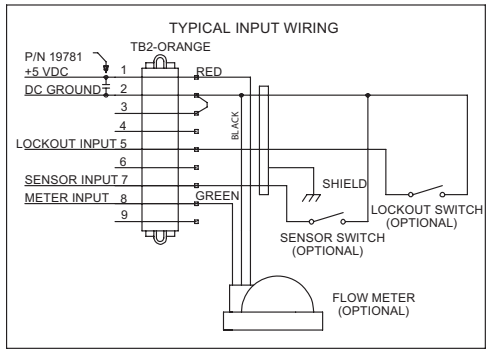
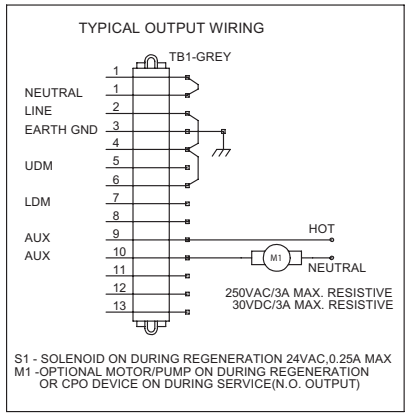
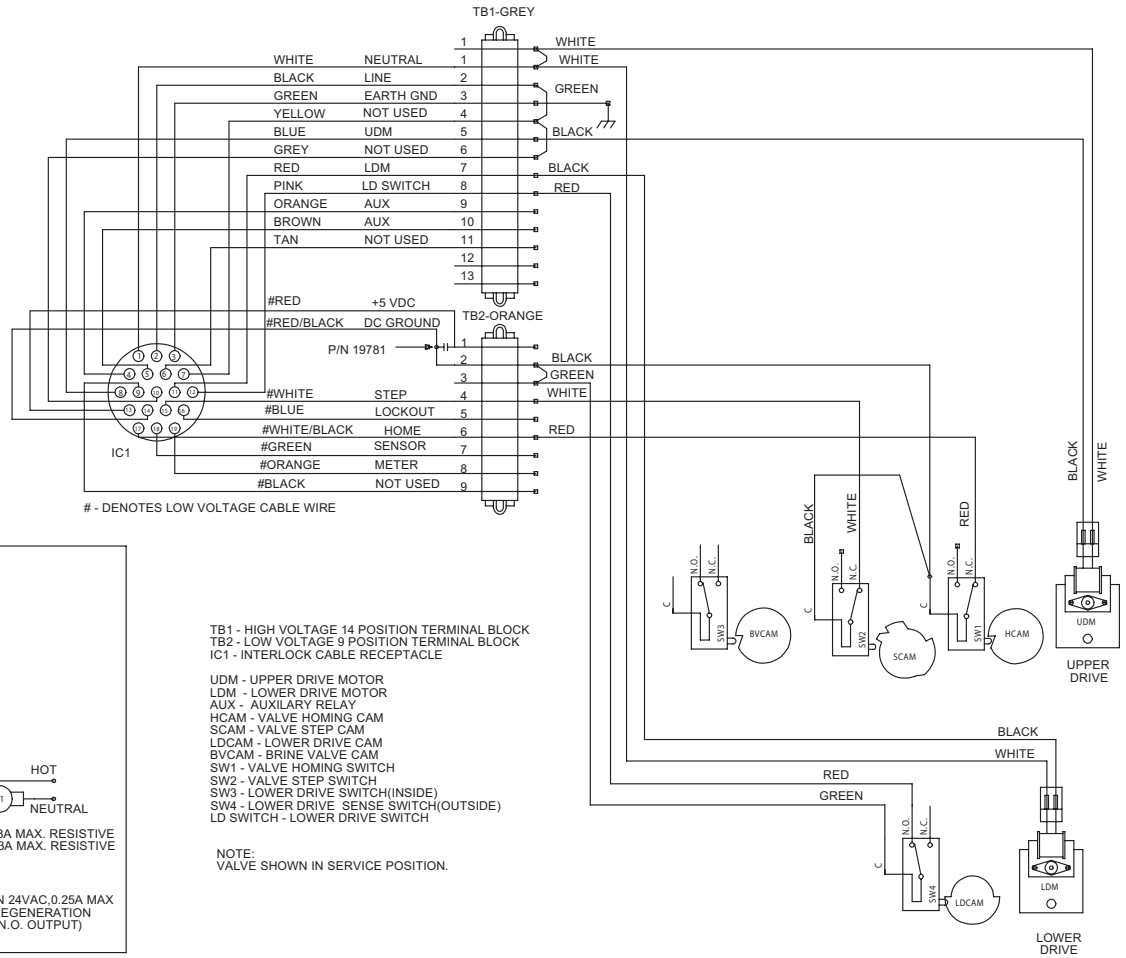

# 3150 REMOTE METER WIRING DIAGRAM

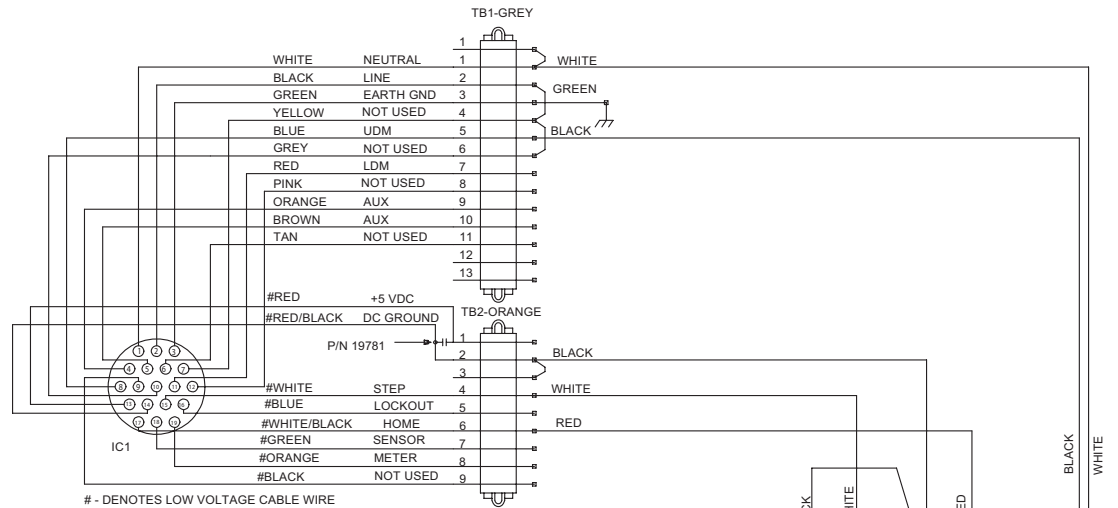

TB1 - HIGH VOLTAGE 14 POSITION TERMINAL BLOCK  
 TB2 - LOW VOLTAGE 9 POSITION TERMINAL BLOCK  
 IC1 - INTERLOCK CABLE RECEPTACLE  
 UDM - UPPER DRIVE MOTOR  
 LDM - LOWER DRIVE MOTOR  
 AUX - AUXILIARY RELAY  
 HCAM - VALVE HOMING CAM  
 SCAM - VALVE STEP CAM  
 BVCAM - BRINE VALVE CAM  
 SW1 - VALVE HOMING SWITCH  
 SW2 - VALVE STEP SWITCH

NOTE:  
 VALVE SHOWN IN SERVICE POSITION.

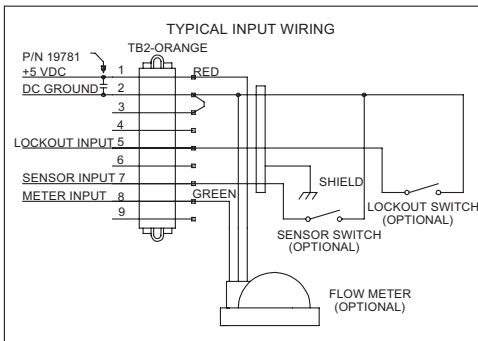
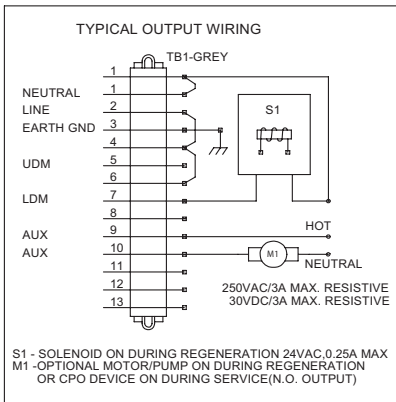
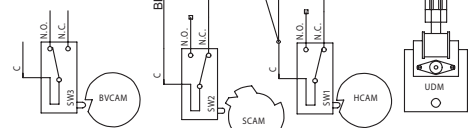



# TROUBLESHOOTING

## Detected Errors

If a communication error is detected, an Error Screen will alternate with the main (time of day) screen every few seconds.

- All units In Service remain in the In Service position.
- All units in Standby go to In Service.
- Any unit in Regeneration when the error occurs completes Regeneration and goes to In Service.
- No units are allowed to start a Regeneration Cycle while the error condition exists, unless they are manually forced into Regeneration.
- When an error is corrected and the error no longer displays (it may take several seconds for all of the units in a system to stop displaying the error message), the system returns to normal operation.

**NOTE: During the error condition the control continues to monitor the flow meter and update the volume remaining. Once the error condition is corrected all units return to the operating status they were in prior to the error. Regeneration queue is rebuilt according to the normal system operation. Or, if more than one unit has been queued for regeneration, then the queue is rebuilt according to which one communicates first.**

Message Displayed	Cause For Error	Correction
Flashing time	Power outage.	Program time by holding UP on Unit #1.
Detected Error = Matching Address	Two or more units programmed with the same valve address number.	Program each unit with unique valve address number in Master Programming.
Detected Error = Program Mismatch	Master program parameters do not match between two or more controls.	Confirm Master Programming for each unit.
Detected Error = No Message #1	No power to Control #1.	Power Control #1.
	Communication Cable to Valve Address #1 bad or missing.	Connect or replace Communication Cable.
Detected Error = No Message #2	No power to Control #2.	Power Control #2.
	Communication Cable to Valve Address #2 bad or missing.	Connect or replace Communication Cable.
Detected Error = No Message #3	No power to Control #3.	Power Control #3.
	Communication Cable to Valve Address #3 bad or missing.	Connect or replace Communication Cable.
Detected Error = No Message #4	No power to Control #4.	Power Control #4.
	Communication Cable to Valve Address #4 bad or missing.	Connect or replace Communication Cable.
Detected Error = E2 Reset Unit	This message appears after a software reset.	Reprogram control using Master Programming section.
Test Mode	Circuit Board was not programmed at factory.	Replace Circuit Board.
Black Squares on screen	Bad Circuit Board.	Replace Circuit Board.
INI on screen for more than 2 minutes	Circuit board not getting feedback from cycle switch.	Inspect Motor - should be rotating.
		Connect wire harness to cycle switch.
		Check Cycle Micro Switch.
CHG on screen for more than 2 minutes	Control programmed incorrectly as 2900 or 3900 valve type.	Reprogram unit as Stager Valve type.





For Fleck Product Warranties visit:  
Fleck para las garantías de los productos visite: } [waterpurification.pentair.com](http://waterpurification.pentair.com)  
Pour Fleck garanties produit visitez le site :



**WATER QUALITY SYSTEMS**

5730 NORTH GLEN PARK ROAD, MILWAUKEE, WI 53209  
P: 262.238.4400 | WATERPURIFICATION.PENTAIR.COM | CUSTOMER CARE: 800.279.9404 | tech-support@pentair.com

<sup>§</sup>For a detailed list of where Pentair trademarks are registered, please visit [waterpurification.pentair.com/brands](http://waterpurification.pentair.com/brands).  
Pentair trademarks and logos are owned by Pentair plc or its affiliates. Third party registered and unregistered trademarks and logos are the property of their respective owners.

41693 REV L NV16 © 2016 Pentair Residential Filtration, LLC All Rights Reserved.